

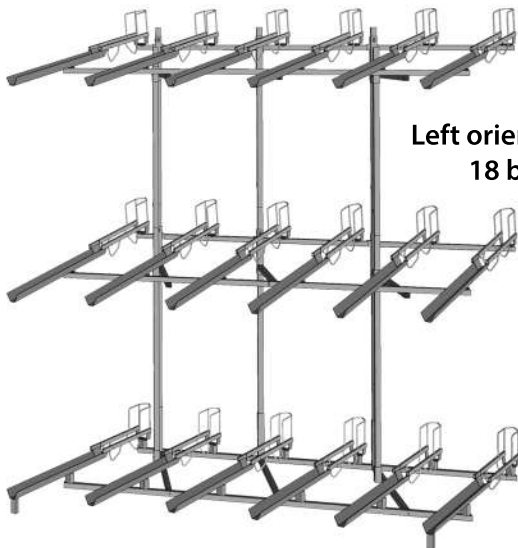

18,21,24 BIKE 3 TIER STRAIGHT FORWARD

Recommended Team Members Needed: 2

Designed & Made in the
USA



Left orientation-
18 bike

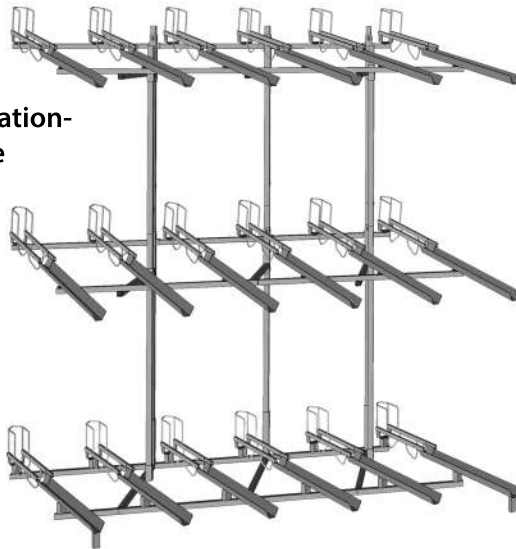

Right orientation-
18 bike

**LOCATE ALL PARTS AND HARDWARE BEFORE
BEGINNING RACK ASSEMBLY!**

**These assembly instructions will picture an *18 bike rack*.
However, assembly steps will be the same for a
21 or 24 bike rack--only rail length, part and hardware
quantities will differ.**

split rail pairings key sheet is on next page

SPLIT RAIL PAIRINGS

24 bike, 16 bike

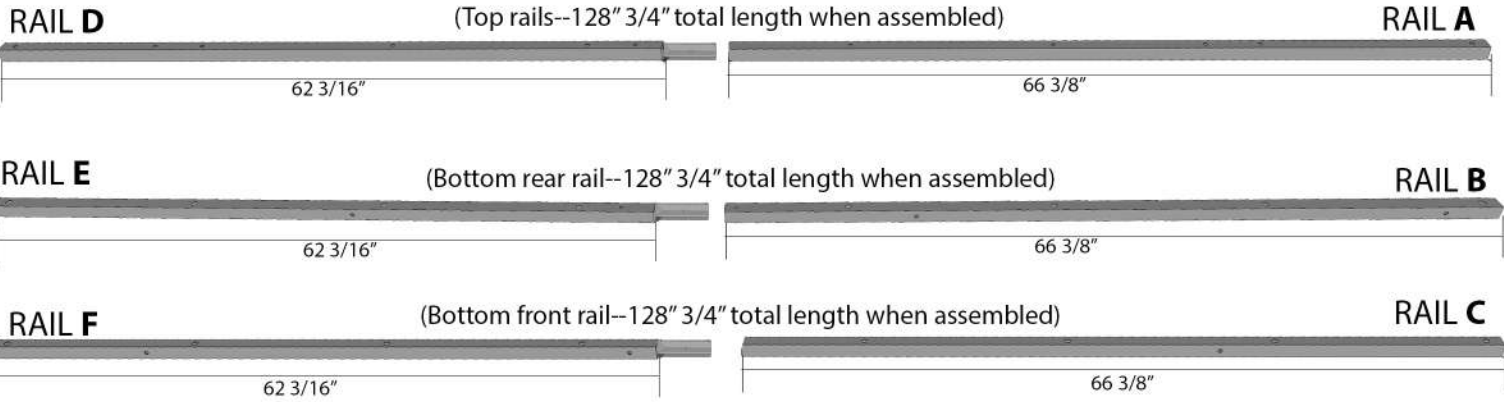

21 bike, 14 bike

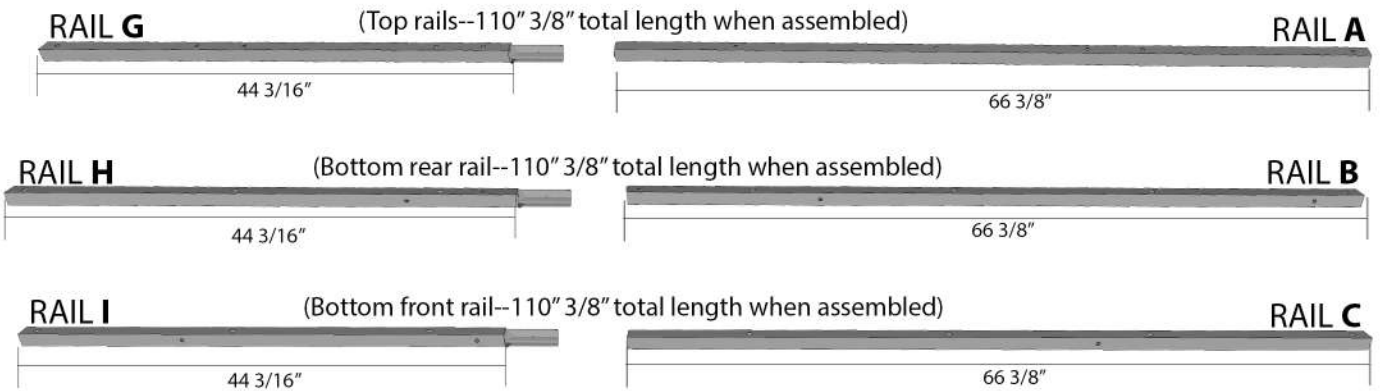

18 bike, 12 bike

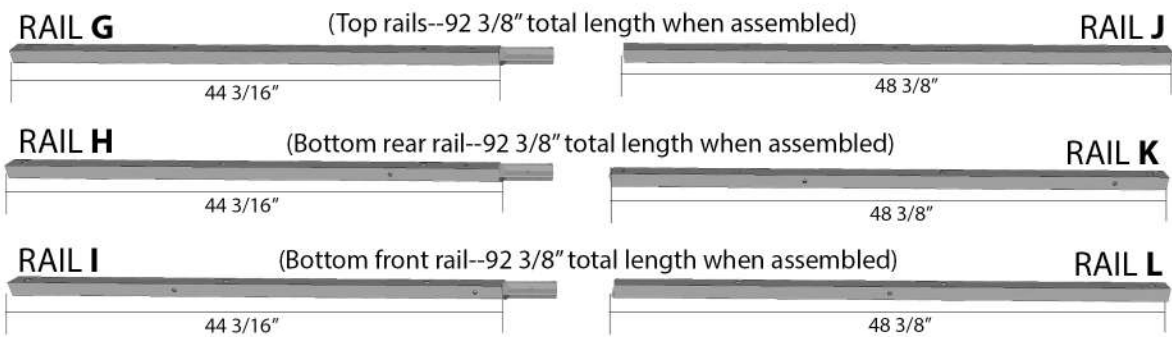

15 bike, 10 bike

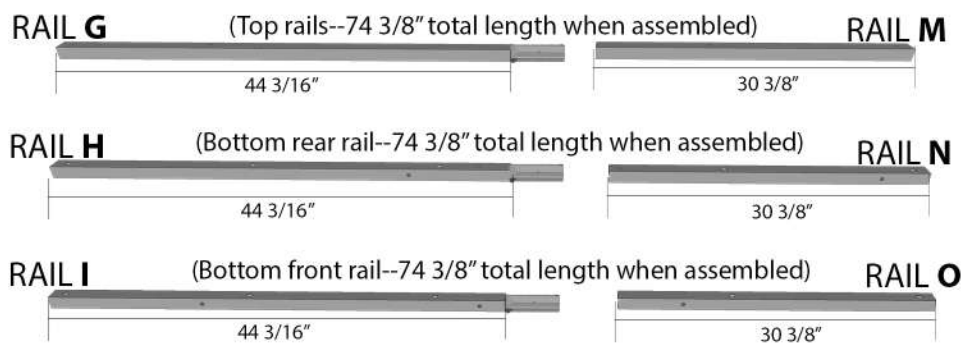



Parts - 18,21,24 BIKE 3 TIER STRAIGHT FORWARD

Tray 

Stabilizer Tray 

48" 3rd Tier Leg 

75" Front Vertical Post 

79" Rear Vertical Post 

RAIL G (top rail front and back) x 4 

RAIL H (rear bottom rail) x 1 

RAIL I (front bottom rail) x 1 

Spacer 

Slide 

Stanchion 

Rack to Wall Mount
(rack support brace and
wall support insert) 

Floor Mount 

Floor Support End 

Floor Support Center 

Upper Main Arm End 

Upper Main Arm Center 

RAIL J (top rail front and back) x 4 

RAIL K (rear bottom rail) x 1 

RAIL L (front bottom rail) x 1 

*These rails can be re-oriented to build a right facing or left facing rack. See **Step 2/pg. 4** for details.

NOTE: The rail letters above are for an 18 bike rack, which will be used for these assembly instructions. If assembling a 21 or 24 bike rack, refer to the **SPLIT RAIL PAIRINGS key sheet included in the assembly instructions for the rails required for your rack.**

Due to the modular nature of rack instructions, part quantities may vary. See packing list for part and hardware quantities.



TOOLS NEEDED:

- *socket wrench with 7/16" and 1/2" sockets
- *7/16" wrench
- *1/2" wrench
- *rubber mallet
- *drill (recommended for rolling bolts on rails)
- *tape measure
- *pencil or chalk

HARDWARE



STEP 1: Assembling Split Rails.

needed: rails G,H,I,J,K,L (for 18 bike), thread rolling bolts, rubber mallet, drill or socket wrench, 7/16" socket

- 1a.** Match the split rails as they are paired on *page 2* (or as they are paired on the *SPLIT RAIL PAIRINGS* key sheet). **All rails are laser cut with their letters.**

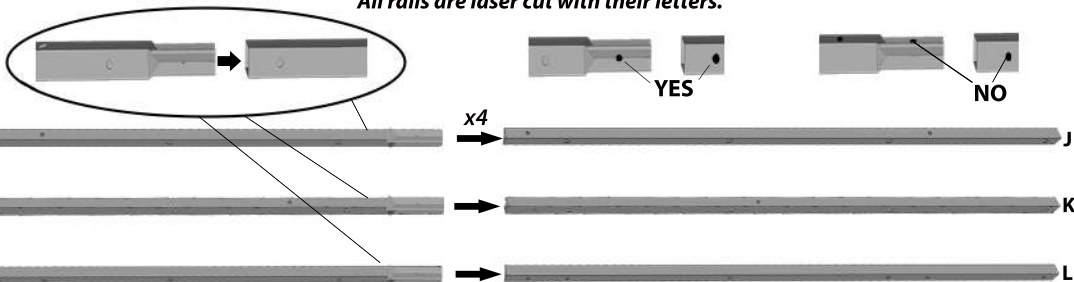

- 1b.** Connect all paired split rails--G and J to make the 4-2nd and 3rd tier top rails, H and K to make the rear bottom rail, and I and L to make the front bottom rail.

NOTES--READ BEFORE CONTINUING RAIL ASSEMBLY!

- *the identification letters of rail sections should be facing **DOWN** and on the ends of the completed rail.
- *be sure holes are lined up before sliding together each pair of rail pieces
- *use a rubber mallet to gently tap on the rail ends if needed to snug each pair together
- *gold rivnuts in the bottom front and bottom rear rail holes should face **UP**



Assembling split rails (contd. from pg. 3)

1c. Secure each assembled rail with a thread rolling bolt. A drill with a 7/16" socket is recommended. If using a hand socket use moderate downward pressure, making sure bolt is straight.

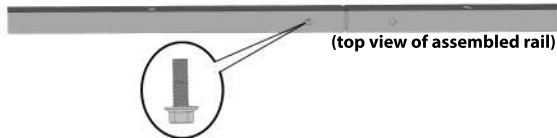

STEP 2: Deciding Rack Orientation/Assembling Base.

needed: Bottom rear rail (H+K), bottom front rail (I+L), floor support ends, floor support center, 5/16" x 2" bolts, 5/16" washers

2a. Lay out both the bottom rear rail (H+K) and bottom front rail (I+L), again making sure the letters of the assembled rails are facing **downward** (note from pg.3).

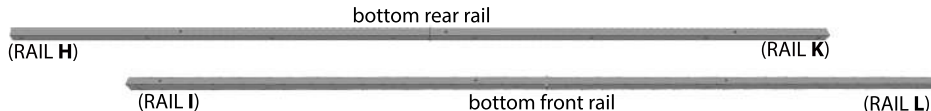

2b. Whichever way the crimped end of the split rail assembly faces, that will be the direction your trays face.



NOTE: rails/rack parts starting with **2c.** will be laid out for a RIGHT orientation. For a left orientation, simply flip each rail 180 degrees (the second illustration in **2c.** shows a left oriented rack).

2c. Lay out bottom **front** rail, then set floor support ends and floor support center behind it, matching the supports with the rail holes, as shown below.

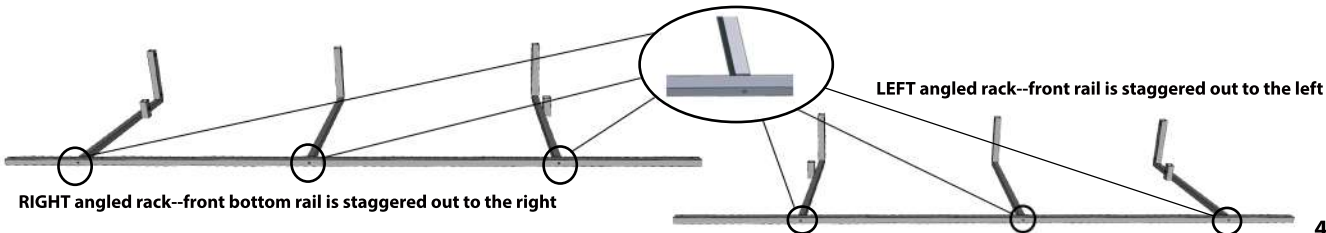



Deciding rack orientation/assembling base (contd. from pg. 4)

2d. Attach floor support ends and floor support center to rails with 5/16" x 2" bolts and 5/16" washers. Tighten bolts.

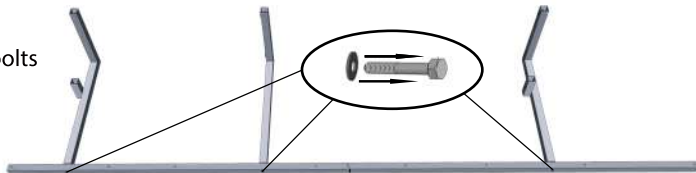

2e. Place rear bottom rail behind floor support ends and floor support center, lining up support holes with rail holes.

2f. Attach rear bottom rail to floor support ends and floor support center with 5/16" x 2" bolts and 5/16" washers. Tighten bolts.

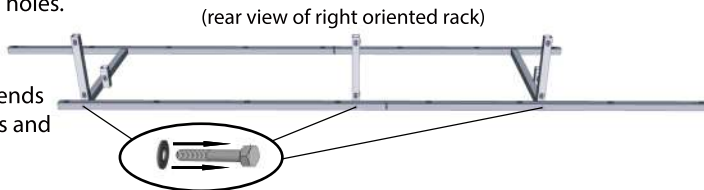

2g. The base framework is now complete. Reference diagrams below before continuing assembly.

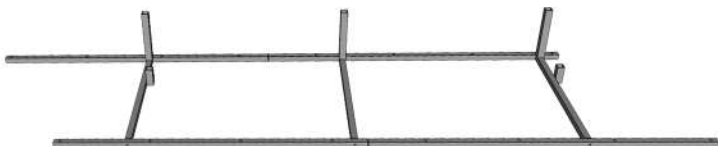

RIGHT ANGLED RACK CHECKLIST:

- *front bottom rail is staggered to the right
- *rear bottom rail is staggered to the left
- *laser cut letters on rails are facing down/the floor
- *crimped ends of assembled rails are facing right



LEFT ANGLED RACK CHECKLIST:

- *front bottom rail is staggered to the left
- *rear bottom rail is staggered to the right
- *laser cut letters on rails are facing down/the floor
- *crimped ends of assembled rails are facing left

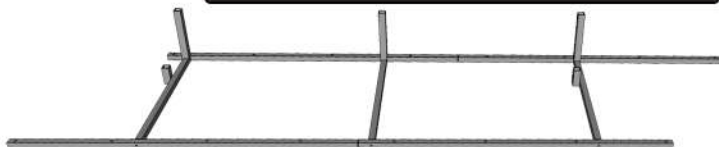



STEP 3: Pre-assemble Trays.

needed: trays, stabilizer trays, stanchions, 1/4" washers, 1/4" x 3/4" bolts, 1/4" stopnuts, 1/2"x1" plugs, 1-1/4" plugs, 7/16" socket, socket wrench, 7/16" wrench

3a. Turn stanchion and low tray upside down. Align the 2 holes on the stanchion with the 2 holes on the low tray.

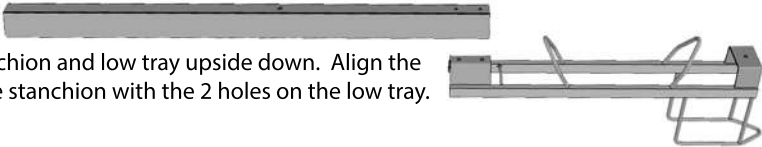

3b. Place a 1/4" washer over a 1/4" x 3/4" bolt.

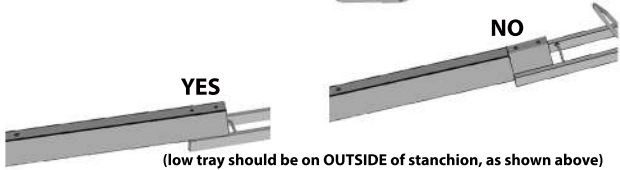

3c. Insert bolt and washer combo into one of the two holes of the tray assembly.

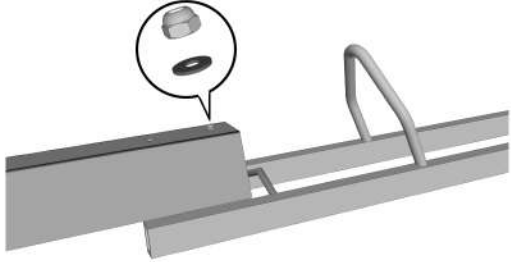
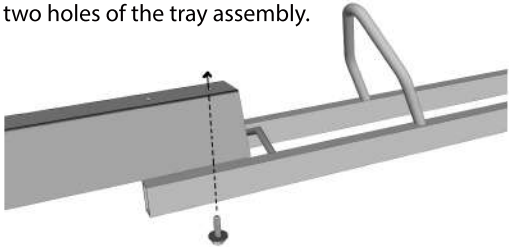

3d. Fasten bolt/washer in place using a 1/4" washer and 1/4" stop nut. Tighten LOOSELY using both the 7/16" socket/wrench and 7/16" wrench.

3e. Repeat steps 3b.-3d. for second hole, then **finish tightening** both bolts and stop nuts with the 7/16" socket/wrench and 7/16" wrench.

3f. Repeat steps 3a.-3e. for all remaining trays (including stabilizer trays) and stanchions.



Pre-assembling trays (contd. from page 6)

- 3i. Insert a 1-1/4" plug on the bottom foot of each of the stabilizer trays.

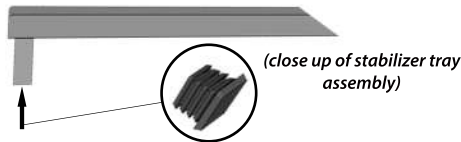

NOTE: the remainder of the instructional diagrams will be for a **right oriented** rack. For a left oriented rack, simply mirror the remaining parts.

STEP 4: Beginning to Build the 2nd Tier.

needed: 75" and 79" vertical posts, 5/16" x 1/2" bolts, 1/2" socket and wrench

- 4a. Insert the 79" vertical posts into the rear vertical portion of the floor supports. The smaller diameter ends of the vertical posts should be on top.

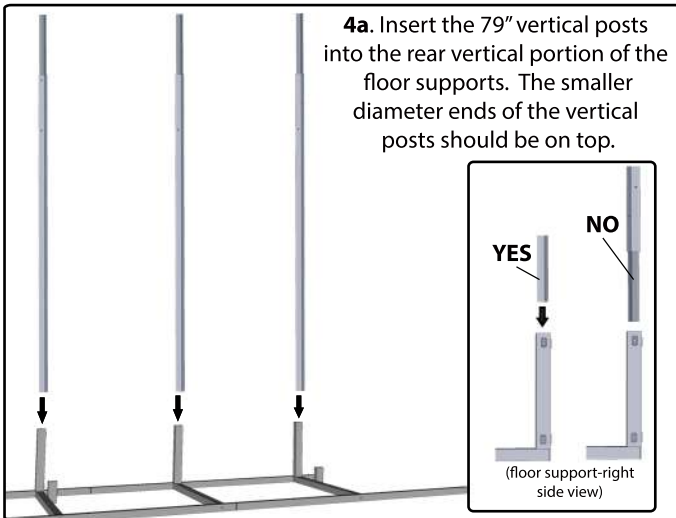

- 4b. Secure 79" posts using (4) 5/16"x 1/2" bolts.

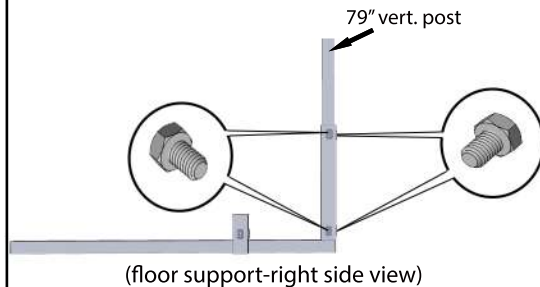

NOTE: After securing/bolting both sets of the vertical posts to the floor supports, there **WILL BE PLAY** in the vertical posts and bottom base assembly until the main arms and top rails are attached.



Beginning to build the 2nd tier (contd. from pg. 7)

4c. Insert the 75" posts into the shorter vertical portion of the floor supports. Again, the smaller diameter ends of the vertical posts should be on top (see close up on Step 4a.)

4d. Secure 75" posts with $5/16"$ x $1/2"$ bolts as done in Step 4b. with 79" vertical posts.

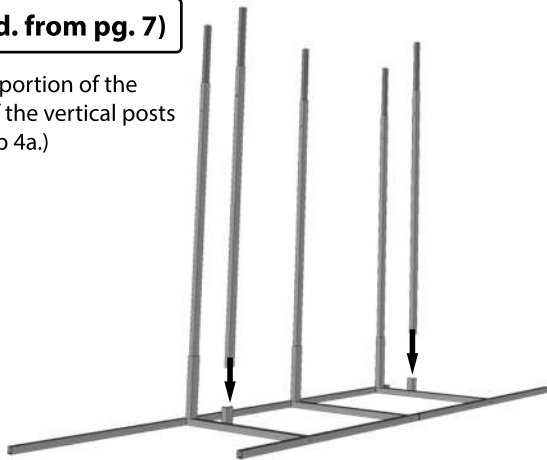

STEP 5: Attaching the Arms.

needed: upper main arm ends, main arm centers, $5/16"$ bolts, tape measure, pencil or chalk

5a. Slide one of the upper main arm ends over a pair of the **end** vertical posts, as shown.

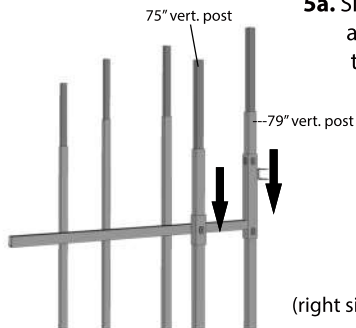

5b. Hold upper main arm end in place by **loosely** inserting (6) $5/16"$ x $1/2"$ bolts into the main arm. Next you will decide the height of the 2nd tier.

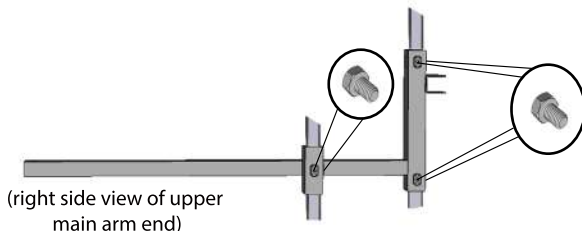



Attaching the arms (contd. from pg. 8)

5c. Adjust upper main arm end up or down the vertical post for desired height for 2nd tier. **50" from the floor to bottom of the upper main arm is recommended.**

5d. Using a tape measure, confirm that upper main arm end is level with **2 measurements**: the height from the bottom of rack base to the front bottom of the upper main arm end, and the back bottom main arm end to back bottom of rack base. **These 2 measurements should be equal.** Use a pencil or chalk to mark the height for ease of adjusting/leveling the arms. Adjust upper main arm end up and down as needed.

5e. Tighten bolts that were inserted in Step 5b.

5f. Repeat steps 5a.-5e. for remaining upper main arm and the upper main arm center.

NOTE: After completing steps 5a-5f, double check that all previous measurements are still equal and that all bolts are tightened before continuing assembly.

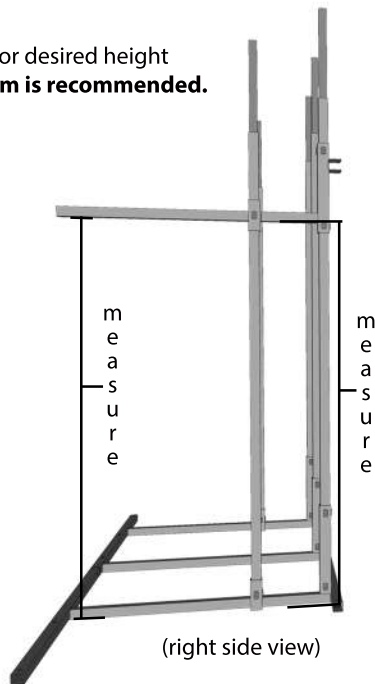



STEP 6: Attaching 2nd Tier Rails.

needed: 2 top rails (G+J), 5/16" x 3" bolts, 5/16" washers, 5/16" stopnuts

- 6a.** Place one of the top rails (Either top rail—they're interchangeable) on top of the front of the upper main arm ends and center arm.

- 6b.** Align holes on the rail with holes in upper main and center arms.

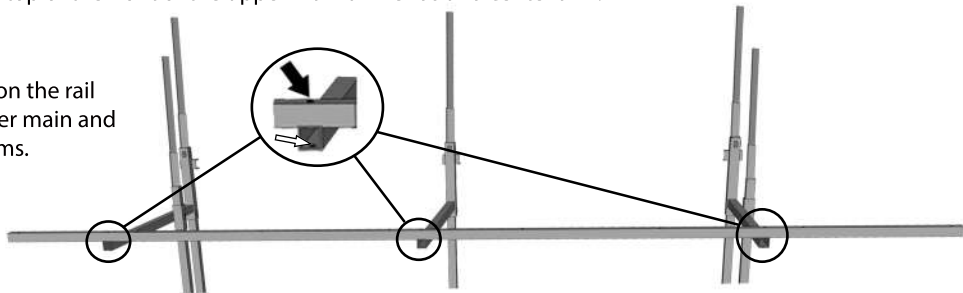

NOTES ON RAIL PLACEMENT FOR BOTH FRONT AND BACK 2nd TIER RAILS:

*letters of top rails should be on the bottom/facing the floor.

*the crimped half rail of each split rail assembly will face the way the rack is oriented—if rack is right angled, the crimped half rail will face right, and vice versa for a left angled rack.

- 6c.** Using a tape measure, make sure right and left top ends of rail are equal to the left and right bottom rail ends.

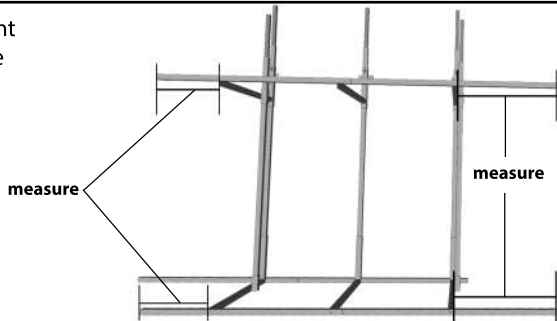



Attaching the 2nd tier rails (contd. from pg 10)

6d. After double checking that upper main arm and rail holes are aligned, attach top front rail to upper main arms/center with 5/16" x 3" bolts, 5/16" washers, and 5/16" stopnuts. Tighten.

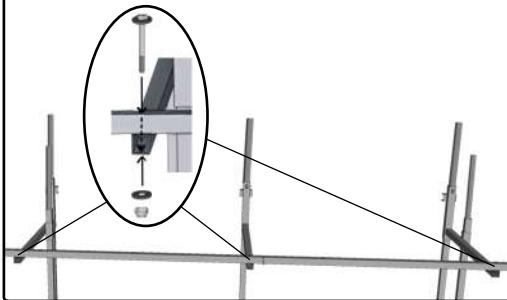

6e. From the *back side* of the rack, place remaining top rail into the C-channels on the back of the upper main arms/center arm.

Follow notes on rail placement on page 10 to ensure proper hole/angle alignment.

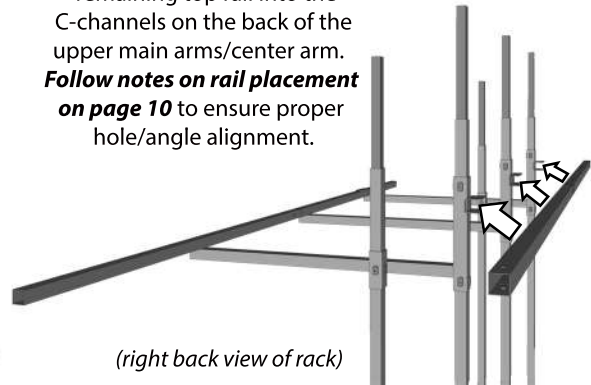

6f. Repeat Step 6c. for rear rail.

6g. Fasten rear top rail to the back of upper main arms/center with 1/4" x 1 3/4" bolts and 1/4" stopnuts.

DO NOT over tighten--hand tighten only.

NOTE: there will be play in the back rail until the trays are attached.

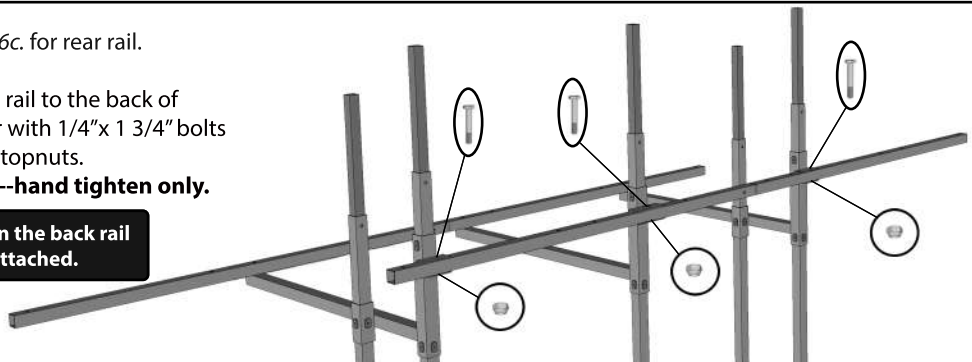



STEP 7: Building the 3rd Tier.

needed: tray assembly, 48" 3rd tier arms, upper main arm ends and main arm center, 5/16" x 1/2" bolts, 5/16" x 2-1/2" bolts, 5/16" washers, 5/16" stopnuts, 1/2" socket and wrench, tape measure, pencil or chalk

7a. Slide a 48" 3rd tier arm over one of the 79" vertical posts. Be sure weld tabs are facing down (see close up below). Repeat for remaining (4) 48" 3rd tier arms.

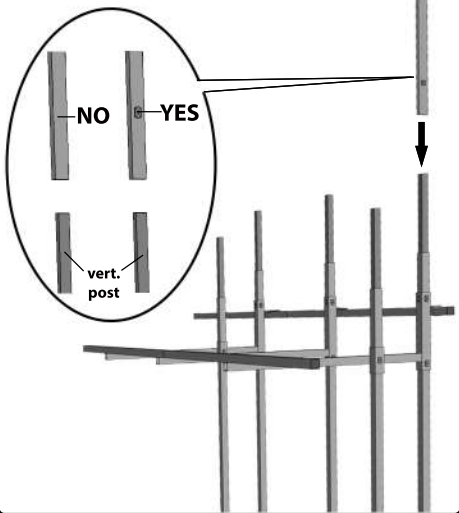

7b. Secure the 48" 3rd tier arms with 5/16" x 1/2" bolts (3 bolts per 3rd tier arm).

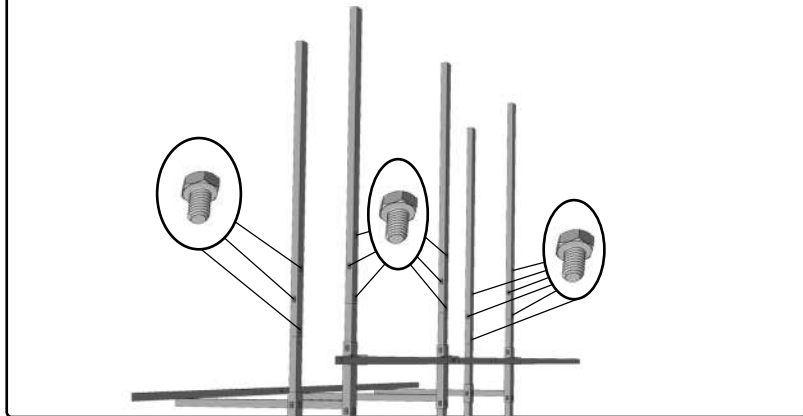

7c. Slide one of the upper main arm ends over a pair of the end 48" 3rd tier arms, as shown.

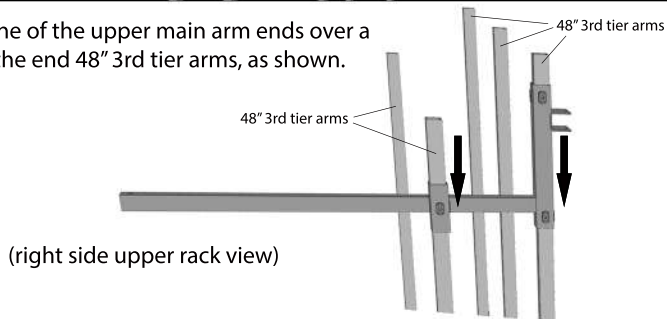



Building the 3rd tier (contd. from pg. 12)

7d. Hold upper main arm in place by **loosely** inserting the (5) 5/16"x 1/2" bolts into the upper main arm end--hand tighten just enough so that the upper main arm stays in place on the 48" 3rd tier arms.

Next you will decide the height of the 3rd tier.

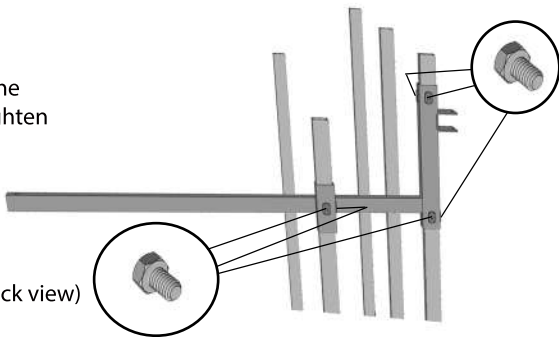

(right side upper rack view)

7e. Adjust upper main arm end up or down the 48" 3rd tier arm for desired height for 3rd tier. **It is recommended** that the rear top of the upper main arm end is flush with the top of the 79" vertical post.

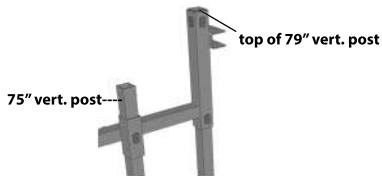

7f. Using a tape measure as with the 2nd tier, confirm that the 3rd tier upper main arm end is level with **2 measurements**: the height from the bottom of the rack base to the front bottom of the upper main arm end, and the back bottom main arm end to the back bottom of rack base. **These two measurements should be equal.** Use a pencil or chalk to mark measurements.

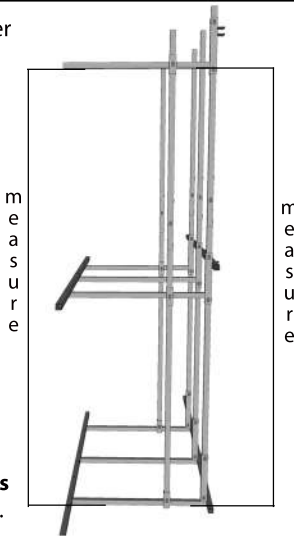

7g. Tighten bolts that were inserted in Step 7d.

7h. Repeat steps **7c.-7g.** for remaining upper main arm end and upper main arm center.



Building the 3rd tier (contd. from page 13)

NOTE: After completing steps 7d-7h, double check that all previous measurements are still equal and that all bolts are tightened before continuing assembly.

7i. Place one of the remaining 2 top rails (they are interchangeable as with the 2nd tier) on top of the 2nd tier front rail. Mark with a pencil or chalk which holes will correspond with the 3rd tier upper main arm ends and center. They should match the 2nd tier front rail.

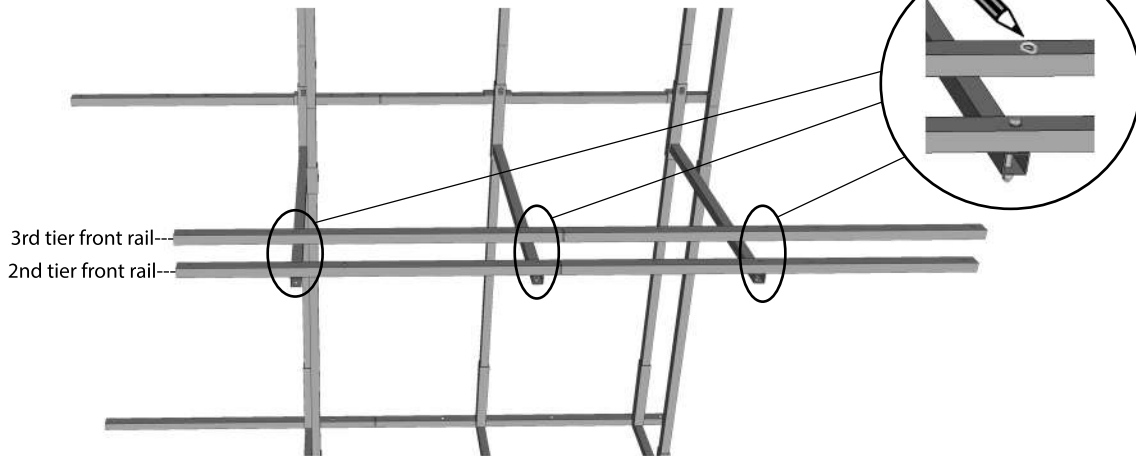

3rd tier front rail---
2nd tier front rail---

7j. Place 3rd tier front rail on top of 3rd tier upper main arm ends and center arm, aligning marked holes with the arm holes. Again, check that laser cut letters on rail are facing DOWN and the crimped rail is facing the same direction as the 2nd tier rail.





Building the 3rd tier (contd. from page 14)

7k. Attach 3rd tier front rail to 3rd tier upper main arm ends and center arm with 5/16" x 3" bolts, 5/16" washers, and 5/16" stopnuts. Tighten.

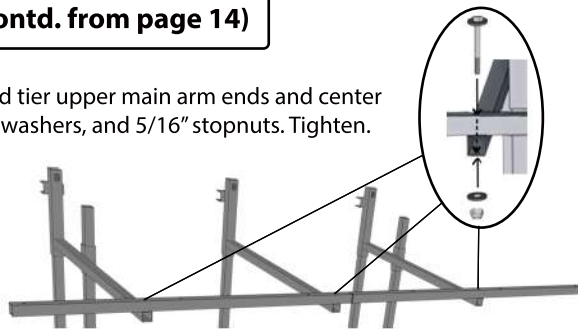

7l. Repeat *Steps 7i-7j* with 3rd tier rear rail, marking rail placement along 2nd tier upper main arm C-channels with a pencil or chalk.

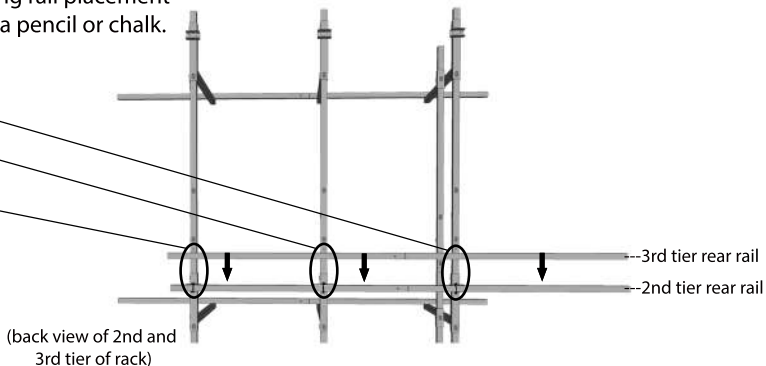
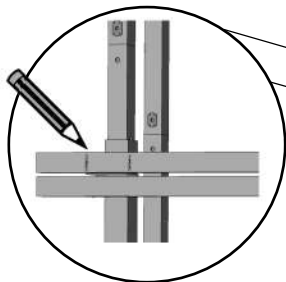

7m. Repeat *Steps 6e.-6g.* (*page 11*) from 2nd tier rear rail with the 3rd tier rear top rail, matching the marks on the 3rd tier rail with the 3rd tier arm C-channels.



STEP 8: Floor and Wall Supports (Optional)

needed: floor mount brackets, 1/4" x 1 3/4" bolts, 5/16" x 1/2" bolts, 1/4" stop nuts, rack support braces, wall support inserts

8a. Attach floor mount brackets in the areas recommended below.

8b. Assemble rack support braces with wall support inserts to make the rack to wall mount, then tighten them together with 5/16" x 1/2" bolts.

8c. Attach rack to wall mounts to top rear rails in the areas recommended on the diagram.

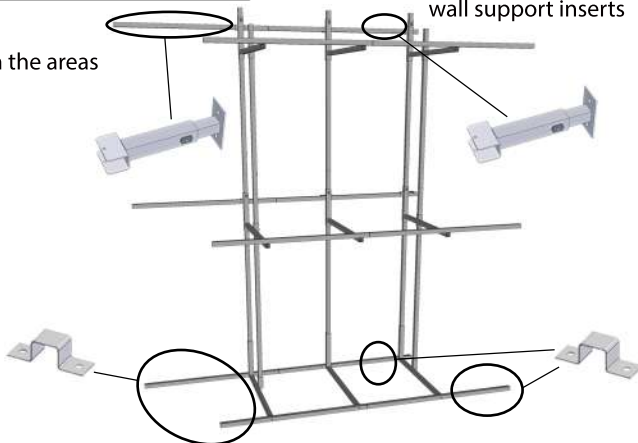

STEP 9: Attach Tray Assemblies to Frame.

needed: all tray/stanchion assemblies, slides, spacers, 5/16" washers, 5/16" x 3-3/4" bolts, 5/16" x 2-1/2" bolts, 5/16" stopnuts, 1/2" socket/wrench

9a. Starting with the bottom/floor tier, place spacers over the riv nut holes (holes with metal inserts) on the rails. Place spacers **at an angle, not flush** with rails.



YES



NO

(top view of assembled rails and floor supports)

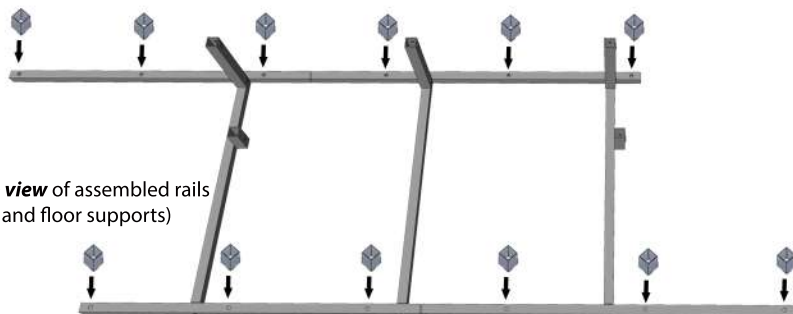



Attach tray assemblies to frame (contd. from pg.16)

9b. Starting on one of the **ends** of the bottom rail assembly, Place a **stabilizer tray assembly** on top of a set of spacers.

Align holes on stanchion and low tray with holes on the rails at the base of the spacers.

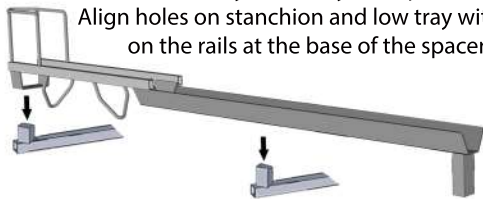

9c. Attach the stabilizer tray assembly and spacers to rails using (2) 5/16" x 3 3/4" bolts and (2) 5/16" washers.

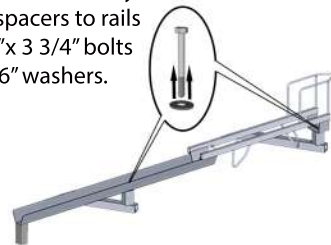

9d. Repeat steps 9b. and 9c. for remaining bottom/floor tier trays, **making sure stabilizer trays are on the ENDS** of the bottom rail assembly.

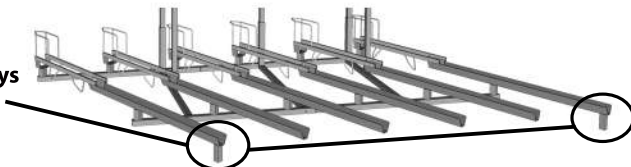

9e. Beginning the 2nd tier, place slides on top of end holes of both the back and front rail. **Angle slides to match angle of trays**, as done in **Step 9a (pg. 16)** with spacers.

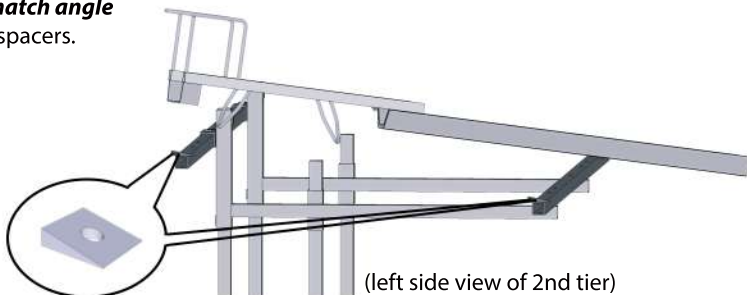



Attach tray assemblies to frame (contd. from pg.17)

9f. Place first tray assembly. Line up bolt holes on tray assembly with the corresponding holes on the top front and top rear rails.

Be sure slides are still placed properly (see pg 17) on top of the rails.

9g. Fasten tray assembly to both top rails with 5/16" x 2-1/2" bolts (2 per tray), 5/16" washers (4 per tray), and 5/16" stopnuts (2 per tray).

9h. Repeat **Steps 9e-9g.** for all remaining 2nd and 3rd tier tray assemblies.

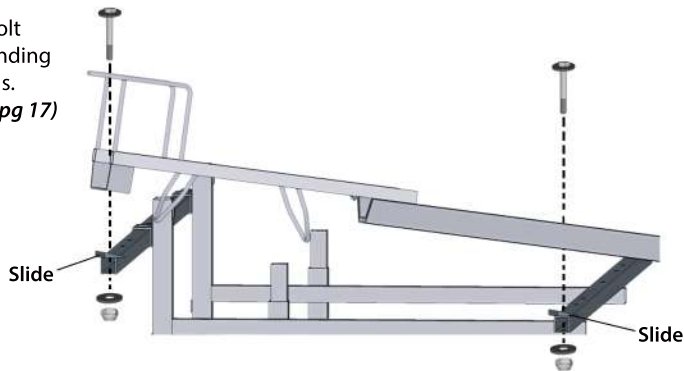

STEP 10: Finishing Touches.

needed: all wrenches, 1-1/4" plugs

10a. Go back through the assembled rack and tighten any loose bolts.

10b. Insert 1-1/4" plugs into all exposed ends of frame--supports, rails, and arms.

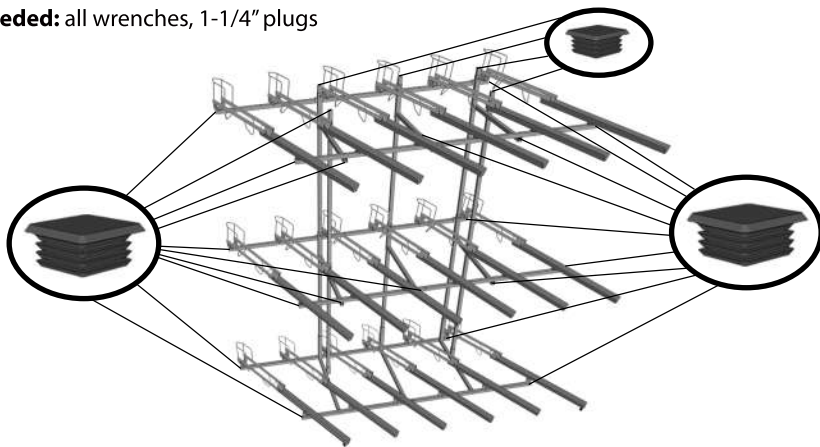



Your rack is now complete!

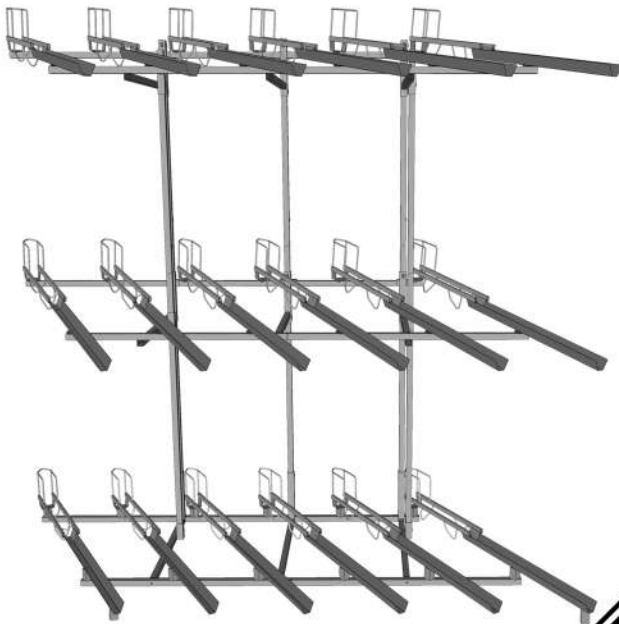

STOP

STOP

BEFORE LOADING BIKES:

It is recommended that the rear derailleur is set on the middle cog and the front derailleur is set on the largest chain ring to prevent chain or derailleur damage.