

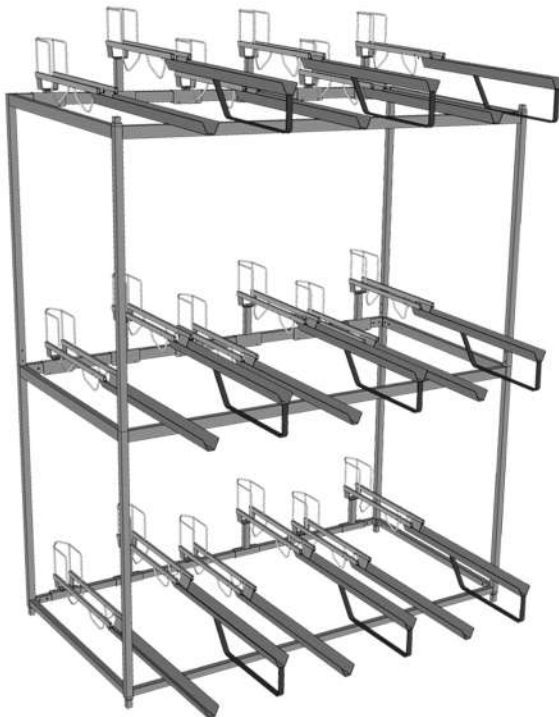

WALL DOUBLE DECKER 3 TIER STARTER

Recommended Team Members Needed: 2

Designed & Made
in the
USA



LOCATE ALL PARTS AND HARDWARE BEFORE BEGINNING RACK ASSEMBLY!

These assembly instructions will picture an 18 bike wall double decker 3 tier rack. However, assembly steps will be the same for any quantity wall double decker 3 tier rack--only part and hardware quantities will differ.



Parts - WALL DOUBLE DECKER 3 TIER STARTER



Safety Stop



Low Slide Top



Low Slide Bottom



High Slide Bottom



Tray



High Slide Large (top slide)



Corner Post



3rd Tier Corner Post

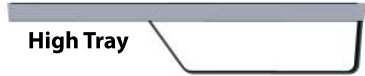

High Tray



43" Top Cross Bar



43" Bottom Cross Bar



Stanchion

Top Rail



Bottom Rail



TOOLS NEEDED:

- *socket wrench with 7/16" and 1/2" sockets
- *7/16" wrench
- *1/2" wrench
- *tape measure
- *pencil or chalk

HARDWARE



1/4" x 1 3/4" bolt



5/16" x 1/2" bolt



5/16" x 3/4" bolt



1-1/4" plug



1/2 x 1" plug



1/4" x 3/4" bolt



1/4" stop nut



5/16" washer



1/4" washer



1" plug

Due to the modular nature of our racks, part quantities may vary.
See packing list for part and hardware quantities.



STEP 1: Building the End Assemblies.

needed: corner posts, top and bottom crossbars, 5/16" x 1/2" bolts, 5/16" washers, 1/2" wrench, 1/2" socket/wrench

1a. Lay 2 corner posts, 1 top crossbar and 1 bottom crossbar on a flat surface. Insert the ears of the corner posts into the crossbars.

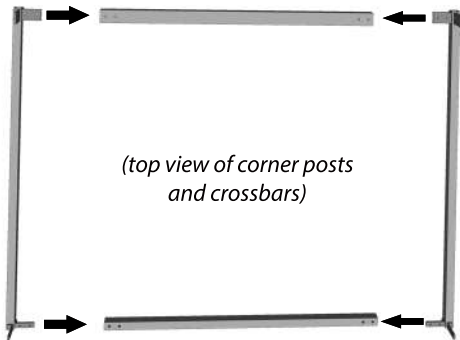

1b. Secure crossbars to end posts with 5/16" x 1/2" bolts and 5/16" washers. **DO NOT FULLY TIGHTEN.**

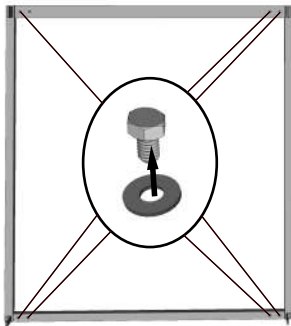

1c. Repeat Steps 1a. and 1b. to complete the second end assembly, again **not fully tightening the hardware.**

STEP 2: Connect the End Assemblies.

needed: end assemblies, bottom rails, top rails, 5/16" x 1/2" bolts, 5/16" washers, 1/2" wrench, 1/2" socket/wrench

2a. Holding one end assembly upright (with smaller ears of the corner post on the bottom), slide one end of each bottom rail over the smaller post ears.

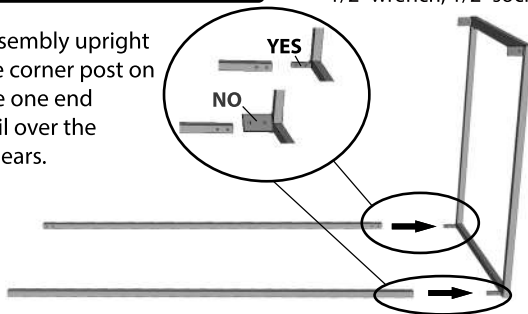



2b. Secure bottom rails to end assembly with 5/16" x 1/2" bolts and 5/16" washers.

Do not fully tighten hardware.

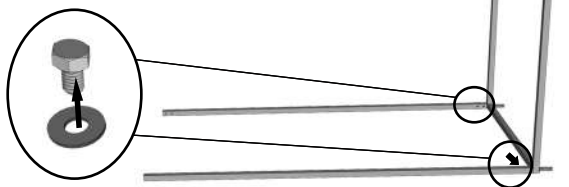

2c. Repeat Step 2a. and 2b. with other end assembly, again **not fully tightening the hardware.**

2d. Slide one of the top rails onto the bigger ears of the end assemblies, lining up the holes on the rails with the holes on the ears.

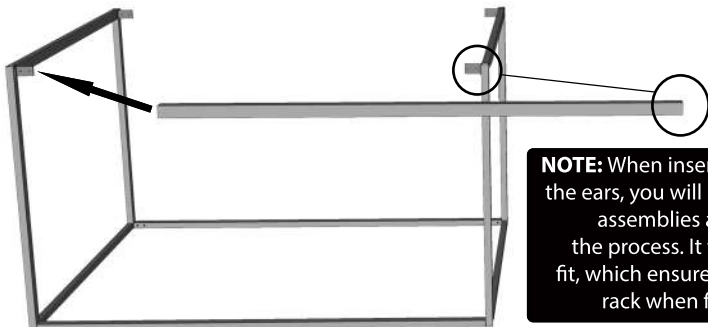

NOTE: When inserting the top rails into the ears, you will have to push the end assemblies a bit outward in the process. It will be a very tight fit, which ensures the stability of the rack when fully assembled.

2e. Secure top rail to end assembly with 5/16" x 1/2" bolts and 5/16" washers.

Do not fully tighten hardware.

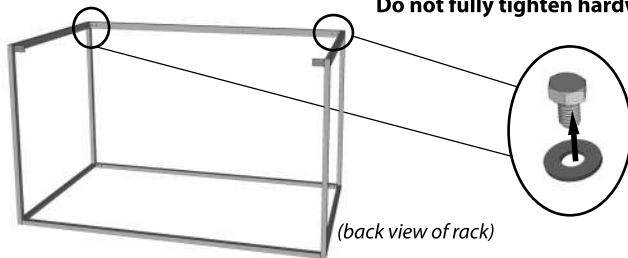

(back view of rack)

2f. Repeat Steps 2d. and 2e. with other top rail.

2g. Finally, go through the assembled frame and snug tighten all bolts.



STEP 3: Safety Stops and Building the 3rd Tier.

needed: 1" plugs, safety stops, 3rd tier corner posts, top crossbars, top rails, 5/16" x 1/2" bolts, 5/16 washers, 1/2" wrench, 1/2" socket/wrench

3a. Push 1" plugs into the *tops* of all safety stops.



3b. Lift one corner of the assembled frame and insert a safety stop with plug *facing the floor*. Repeat with the 3 remaining frame corners.

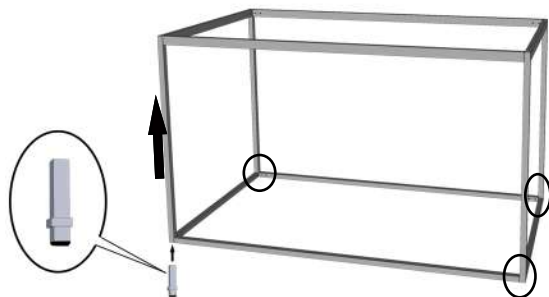

3c. Insert the 3rd tier corner posts into the tops of the lower corner posts.

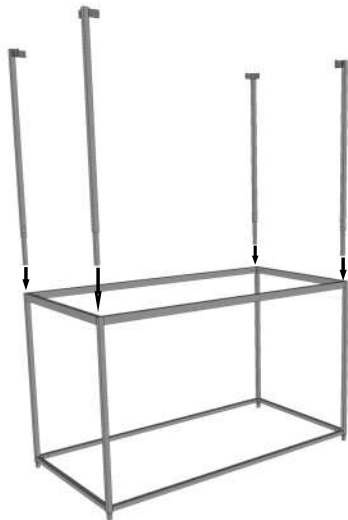

3d. Insert remaining top crossbars into ears of 3rd tier corner posts.





Safety stops and building the 3rd tier (contd. from pg. 5)

- 3e.** Secure crossbars to end posts with 5/16" x 1/2" bolts and 5/16" washers. **DO NOT FULLY TIGHTEN.**

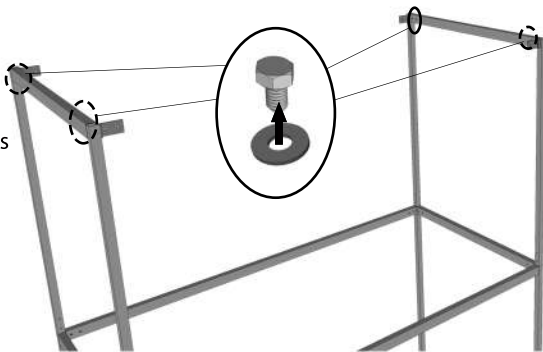

- 3f.** Slide one of the top rails onto the ears of the 3rd tier end assemblies, lining up the holes on the rails with the holes on the ears.

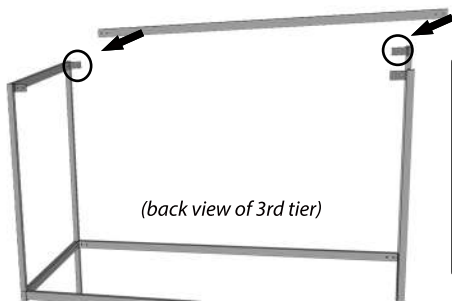

NOTE: When inserting the top rails into the ears, you will have to push the end assemblies a bit outward in the process--*you may have to slightly re-loosen the 2nd tier rails and crossbars to do this.* It will be a very tight fit, which ensures the stability of the rack when fully assembled.

- 3g.** Secure top rail with 5/16" x 1/2" bolts and 5/16" washers.

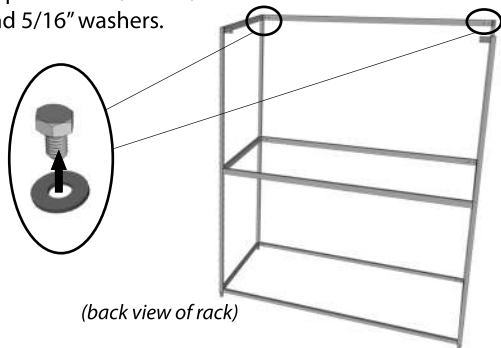

3h. Repeat Steps 3f. and 3g. with remaining top rail.

3i. Go back through completed frame and snug tighten all loose bolts.



Safety stops and building the 3rd tier (contd. from pg. 6)

3j. Place remaining 2 safety stops in front top corners of rack frame, with the plugs facing **up**.

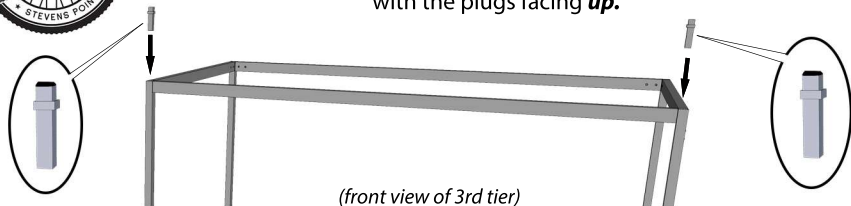

(front view of 3rd tier)

STEP 4: Attaching Slides.

needed: all low slides, all high slides, 1/4" x 1 3/4" bolts, 1/4" stopnuts, pencil or chalk

RECOMMENDED SLIDE SPACING:

106" rails---3 7/8" from end of rail, 7 5/8" between slides
95" rails---3 3/4" from end of rail, 7 1/2" between slides
82" rails---3 3/4" from end of rail, 7 1/2" between slides

4a. Starting on the bottom tier, fit bottom low slides and bottom high slides over the rear rail, with C channel of each slide facing the back of the rack (see close up).

Alternate low and high slides, starting with low slide. **See note on recommended slide spacing above.** Use a pencil or chalk to mark spacing.

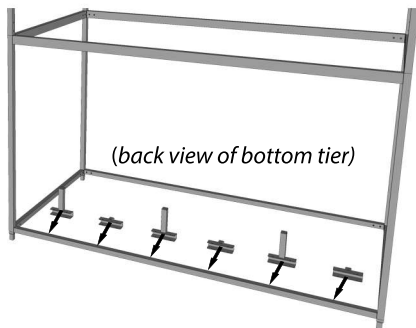

(back view of bottom tier)

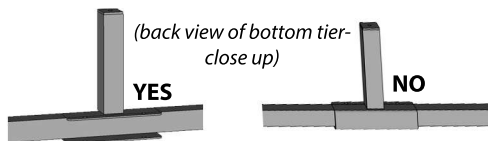

(back view of bottom tier—close up)

YES

NO

4b. Secure slides to rail using 1/4" x 1 3/4" bolts and 1/4" stopnuts.

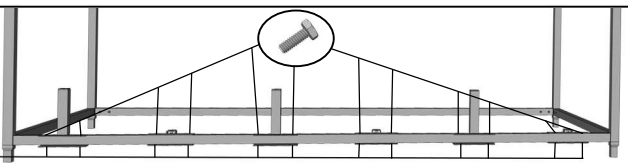



Attaching Slides (contd. from pg. 7)

- 4c.** Repeat steps 4a.-4b. with 2nd and 3rd tier top slides, again noting distance between each slide and marking with a pencil or chalk. Slide spacing and alternating should be identical to bottom tier.

STEP 5: Tray Assembly.

needed: stanchions, trays, high trays, 1/4" washers, 1/4" stopnuts, 1/2"x 1" plugs, 7/16" socket/wrench

- 5a.** Turn a stanchion and a tray upside down. Align the 2 holes on the stanchion with the 2 holes on the tray.

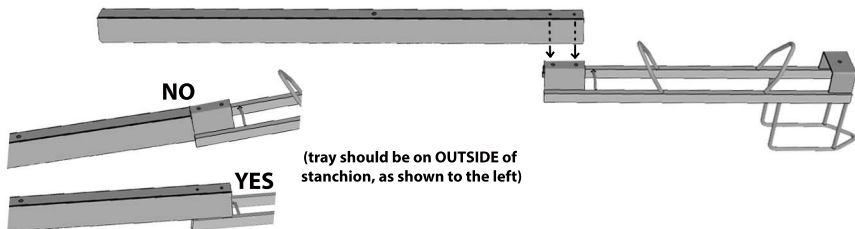

- 5b.** Place a 1/4" washer over a 1/4" x 3/4" bolt.

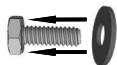

- 5c.** Insert bolt and washer combo into one of the two holes of the tray assembly.

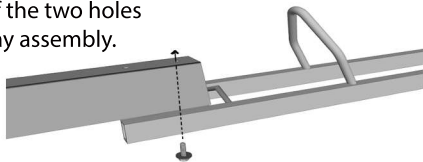

- 5d.** Fasten bolt/washer in place using a 1/4" washer and 1/4" stop nut. Tighten **LOOSELY** using both the 7/16" socket/wrench and 7/16" wrench.

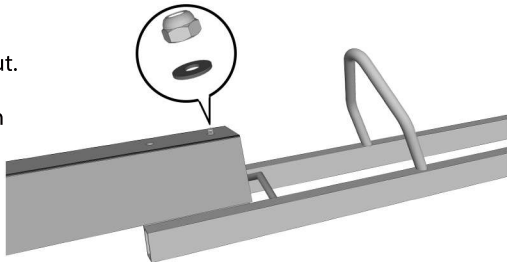

- 5e.** Repeat steps 5b.-5d. for second hole, then finish tightening both bolts and stop nuts with the 7/16" socket/wrench and 7/16" wrench.

- 5f.** Repeat steps 5a.-5e. for all remaining trays, high trays, and stanchions.



Tray Assembly (contd. from pg. 8)

- 5g.** Insert 1/2" x 1" plugs into the front and back of the stanchion as shown. You will need 4 plugs for each stanchion.

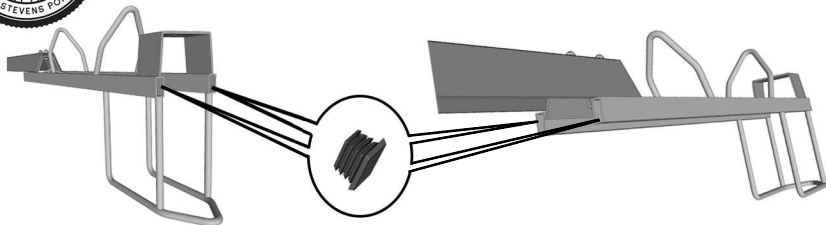

- 5h.** Repeat step 5g. for all remaining assembled trays.

Your trays are now complete!

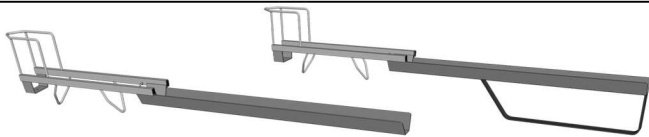

STEP 6: Attaching Trays to Frame.

needed: all tray assemblies, 1-1/4" plugs, safety stops, 5/16" x 1/2" bolts, 5/16" washers, 5/16" x 3/4" bolts

- 6a.** Starting on the bottom tier, align tray assembly holes with fastened bottom slides--low tray assemblies match with bottom low slides, high tray assemblies match with bottom high slides.

(back view of bottom tier)

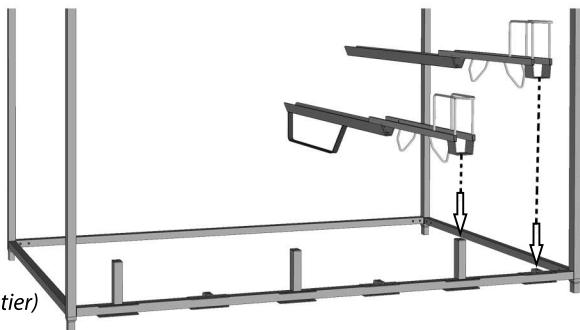

- 6b.** Attach low tray to low bottom slide with a 5/16" x 1/2" bolt and a 5/16" washer. Attach high tray to bottom high slide with a 5/16" x 3/4" bolt and a 5/16" washer.

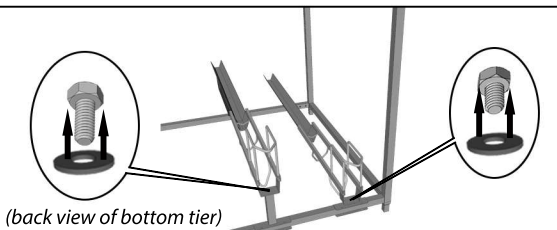

(back view of bottom tier)



Attaching Trays to Frame (contd. from pg. 9)

6c. Repeat steps *6a.* and *6b.* for remaining trays on the bottom tier.

6d. Repeat Steps *6a.-6c.* for remaining trays on the 2nd and 3rd tier.
Attach all trays to 2nd tier *before* attaching trays to the 3rd tier.

STEP 7: Finishing Touches. **needed:** 1-1/4" plugs, safety stops

7a. Place safety stops into the top front corners of rack. Place 1-1/4" plugs in the top back corners.

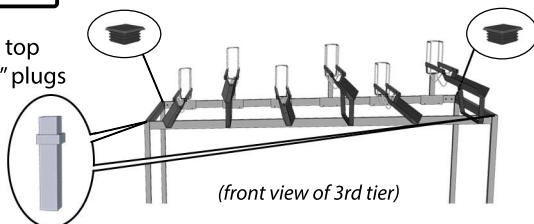

(front view of 3rd tier)

Your rack is now complete!

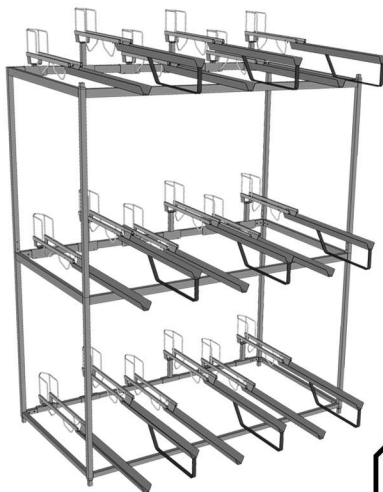

STOP

STOP

BEFORE LOADING BIKES:

It is recommended that the rear derailleur is set on the middle cog and the front derailleur is set on the largest chain ring to prevent chain or derailleur damage.