

WALL DOUBLE DECKER STARTER

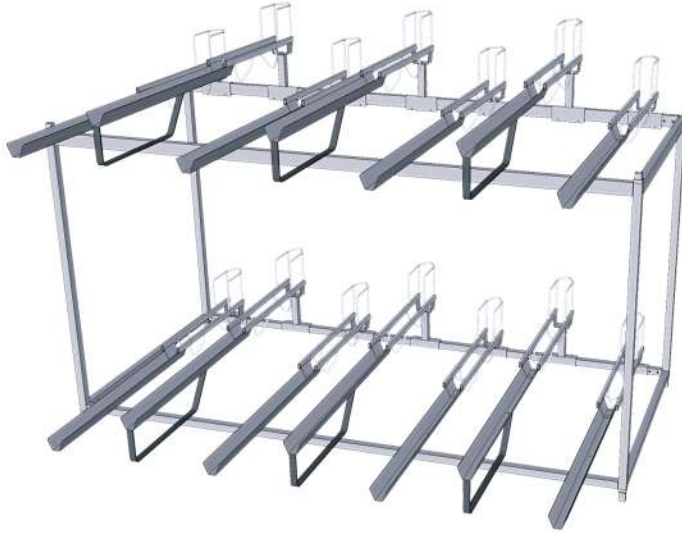

HARDWARE

5/16" x 1/2"	BOLTS
5/16" x 3/4"	BOLTS
5/16"	WASHERS
1/4" x 3/4"	BOLTS
1/4" x 1-3/4"	BOLTS
1/4"	WASHERS
1/4"	STOPNUTS
1/2" x 1"	BLACK PLUGS
1"	BLACK PLUGS
1-1/4"	BLACK PLUGS

TOOLS

(2) 7/16"	WRENCHES
(1) 1/2"	WRENCH

PARTS LIST



BOTTOM HIGH SLIDE



BOTTOM LOW SLIDE



TOP HIGH SLIDE



TOP LOW SLIDE



BOTTOM CROSSBAR



TOP CROSSBAR



CORNER POST



LOW TRAY



STANCHION



SAFETY STOP

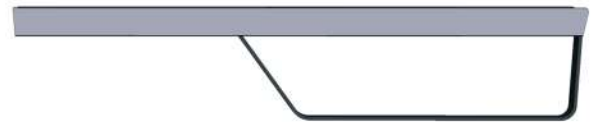

HIGH TRAY



BOTTOM RAIL



TOP RAIL



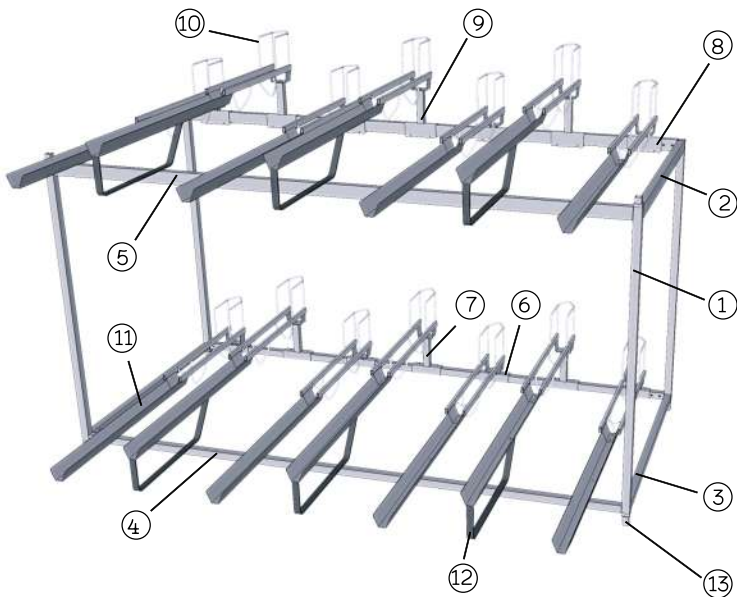

- | | |
|---------------------|----------------------|
| 1. CORNER POST | 7. BOTTOM HIGH SLIDE |
| 2. TOP CROSSBAR | 8. TOP LOW SLIDE |
| 3. BOTTOM CROSSBAR | 9. TOP HIGH SLIDE |
| 4. BOTTOM RAIL | 10. STANCHION |
| 5. TOP RAIL | 11. LOW TRAY |
| 6. BOTTOM LOW SLIDE | 12. HIGH TRAY |
| | 13. SAFETY STOP |

STEPS 1-8: ONLY LOOSELY TIGHTEN THE BOLTS

STEP ONE: (CREATE TWO END ASSEMBLIES):

Locate (2) Corner Posts, (1) Bottom Crossbar, and (1) Top Crossbar. Create an End Assembly by laying parts on a flat surface, inserting the ears on the Corner Posts into the Crossbars as shown.

Secure using 5/16" x 1/2" Bolts and 5/16" Washers.

Repeat once more with the remaining Corner Posts and Crossbars to create another End Assembly.

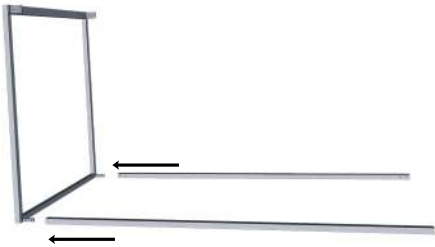
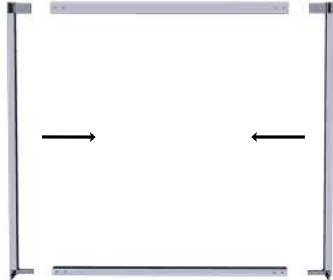

STEP TWO:

Locate the (2) Bottom Rails. While holding one End Assembly upright with the small ears on the bottom, slide the ends of the rails over the ears as shown. Secure using 5/16" x 1/2" Bolts and 5/16" Washers.

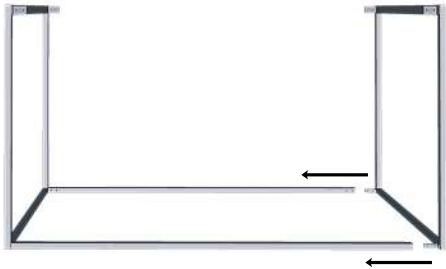

STEP THREE:

Mirror the same process on the other side of the structure. Secure using 5/16" x 1/2" Bolts and 5/16" Washers.

STEP FOUR:

Locate a Top Rail. Slide one end over one of the Corner Post ears, while negotiating the other end over the corresponding ear on the opposite side of the rack.

NOTE: IT MAY TAKE A LITTLE FORCE TO GET THE RAIL ONTO BOTH EARS.

Secure using 5/16" x 1/2" Bolts and 5/16" Washers.

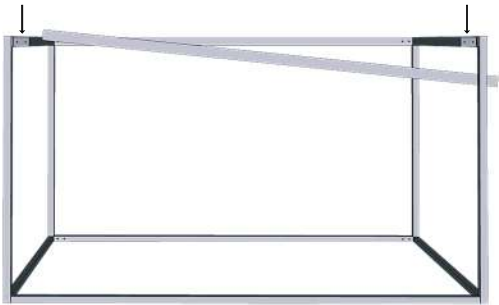
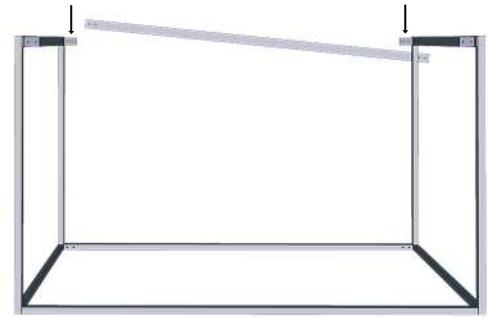

STEP FIVE:

Repeat Step Four with the remaining Top Rail. Now your structure is complete.

GO BACK AND RE-TIGHTEN ALL BOLTS ON THE STRUCTURE.

STEP SIX:

Locate the Safety Stops. Insert 1" Black Plugs into the top of the Safety Stops.

Lift each corner of the structure and slide the long side of a Safety Stop into the bottom of the Corner Posts, as shown.

Next, insert Safety Stops into the top front vertical tubes of the Corner Posts.



STEP SEVEN:

Locate the Bottom Slides. Alternating low and high, slide them over the Bottom Rail at the rear of the rack, as shown. Once satisfied with the spacing, secure using 1/4" x 1-3/4" Bolts and 1/4" Stopnuts.

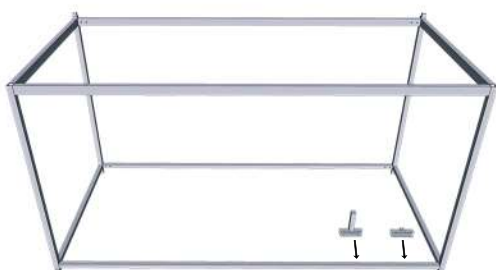

View from the Back

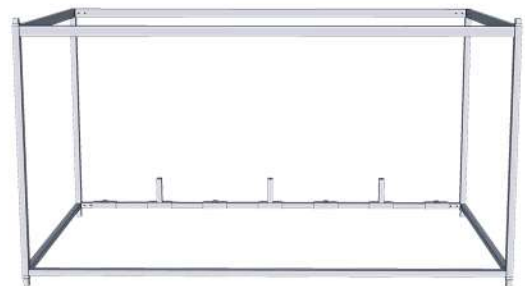

Front View





STEP EIGHT:

Locate the Top High and Low Slides. Starting from the end of the rack, alternate high and low to match the bottom tier.

Secure using 1/4" x 1-3/4" Bolts and 1/4" Stopnuts.

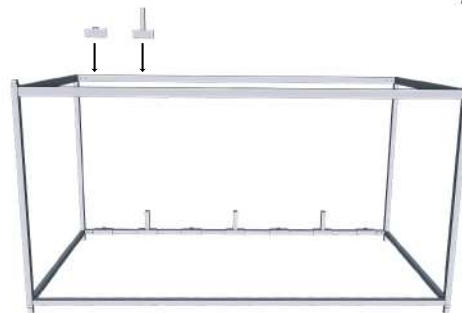

STEP NINE: TRAY ASSEMBLY (HIGH and LOW TRAYS)



Locate the Stanchions and Trays. Flip a stanchion and tray upside down. Align the 2 holes in the stanchion with the 2 holes in the tray. The tray should be on the outside of the stanchion, as shown.



Place a 1/4" washer over a 1/4" x 3/4" bolt. Insert the assembly through one of the holes.

Tighten loosely with a 1/4" washer and 1/4" stopnut.

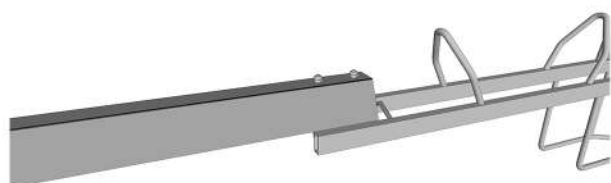

Repeat in the open hole, as shown. Tighten using two wrenches.

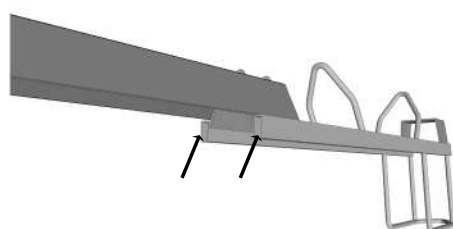

Insert (2) 1/2" x 1" Plugs into the open holes in the front of the stanchion, as shown.

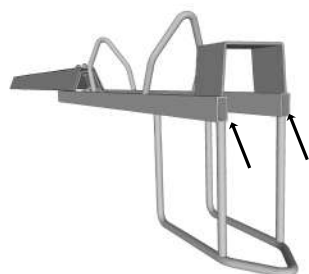

Insert (2) 1/2" x 1" Plugs into the back of the stanchion, as shown.

Your tray is now complete!



STEP TEN:

Attach Low and High Tray Assemblies to the bottom tier. Low Trays attach to Bottom Low Slides and High Trays attach to Bottom High Slides. Align the back hole of the tray assembly with the hole on the slide.

Attach Low Trays using 5/16" x 1/2" Bolts and 5/16" Washers.

Attach High Trays using 5/16" x 3/4" Bolts and 5/16" Washers.



STEP ELEVEN:

Repeat Step 10 and attach the remaining Tray Assemblies to the Top Tier.

STEP TWELVE:

Finish the rack by placing 1-1/4" Black Plugs into the open vertical tubes on the back of the rack.

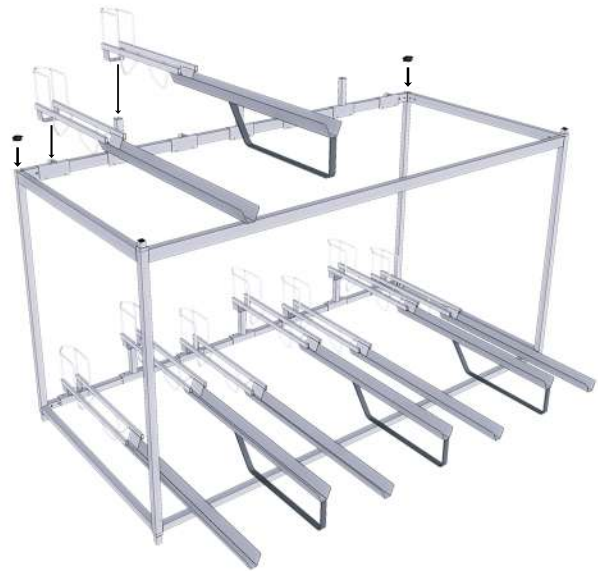

YOUR RACK IS NOW COMPLETE!



Before loading bikes: If your bike has a rear derailleur it is recommended that the rear derailleur is set to the lowest gear (the largest rear chain ring) to prevent chain or derailleur damage

