

Sloped Double Decker ASSEMBLY INSTRUCTIONS

Rudy Rack

P.O. Box 133
Plover, WI 54467
800-434-6442
rudyrack.com

Pictured below is a Starter Section.

1. Assemble the STARTER SECTION as shown below. Locate 51" CORNER and , 55" CORNER POSTS, 33" CROSS BARS and RAILS.
2. The RAILS and CROSS BARS fit over the "ears" on the CORNER POSTS . Place a 5/16" x 3/4" bolt into each WELD-TAB and tighten it in place. Be sure each RAIL and CROSS BAR fits completely over the "ear" before tightening it.

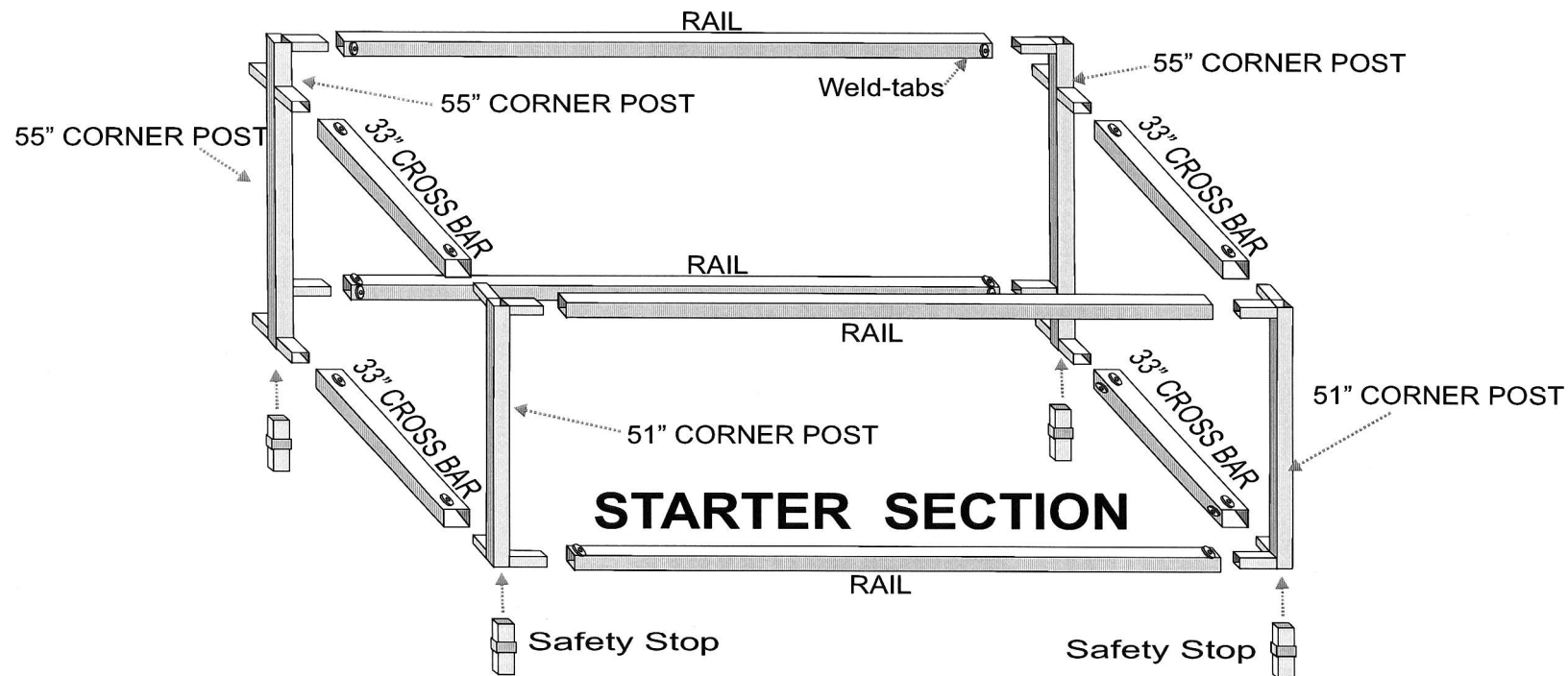

NOTE: The Sloped Double Decker is available in 6 or 8 bike sections. The only difference between these versions is the length of the RAILS and the number of trays on each tier. Assembly is the same for all versions of the Sloped Double Decker.

Sloped Double Decker ASSEMBLY INSTRUCTIONS

3. Starting from the left, begin placing LOW SLIDES and HIGH SLIDES onto the rear RAIL of the STARTER SECTION. Be sure to alternate slides in a LOW-HIGH format. (This allows handlebars to overlap.)
4. Place a 1/4" x 2" bolt through the pre-drilled holes on each HIGH SLIDE and LOW SLIDE. Attach a 1/4" nut to each bolt to secure the slide to the rack. (Note: if the bolt on the slide is tightened down, the tray will only pivot. If the bolt on the slide is left loose, the tray will slide and pivot, making it easier to remove bikes from the rack.)
5. Use the provided washers and nylon stop-nuts, attach LOW TRAYS to the LOW SLIDES and HIGH TRAYS to the HIGH SLIDES. Trays DO NOT attach through the hole on the rear of the tray - there is a second hole 17" from the end of the tray - mount the slide through this hole. A portion of the tray will hang off the back side of the rack. Tighten the nylon stop-nut to secure each tray in place. (Do not over tighten - just "snug".)
6. Place a SAFETY STOP on the two front corners of the rack. (This prevents trays from pivoting off the rack.)
7. A variety of black plastic end-caps are included. Plug them into the exposed ends of tubing for a finished look.

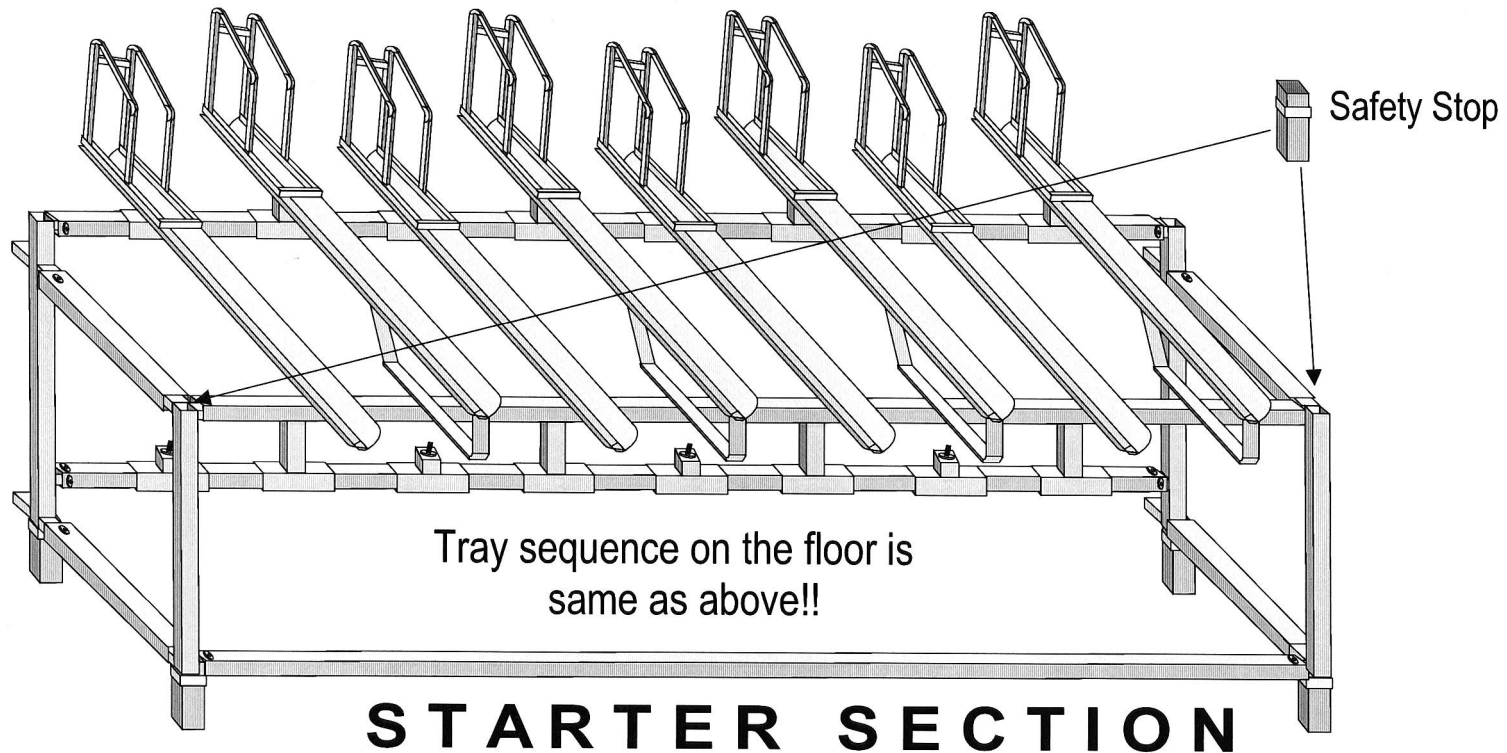
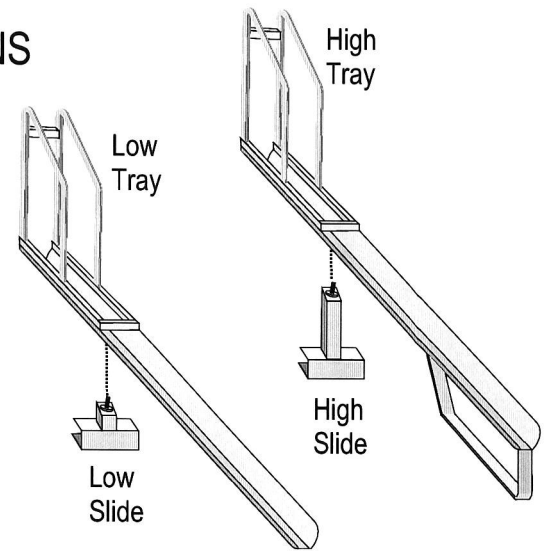

NOTE: The Sloped Double Decker shown here has 8 trays per section. If you have a 6-bike section, follow these instructions, putting 6 trays on to each section of the rack.