

STRAIGHT FORWARD
2 TIER 8 & 10 BIKES

- HARDWARE**
- 5/16" x 2-1/2" Bolts
 - 5/16" x 2" Bolts
 - 1/4" x 3/4" Bolts
 - 5/16" x 1/2" Bolts
 - 5/16" x 3" Bolts
 - 1-1/4" Black Plugs
 - Black Rectangular Plugs
 - 5/16" Washers
 - 1/4" Washers
 - 5/16" Stopnuts
 - 1/4" Stopnuts
- 

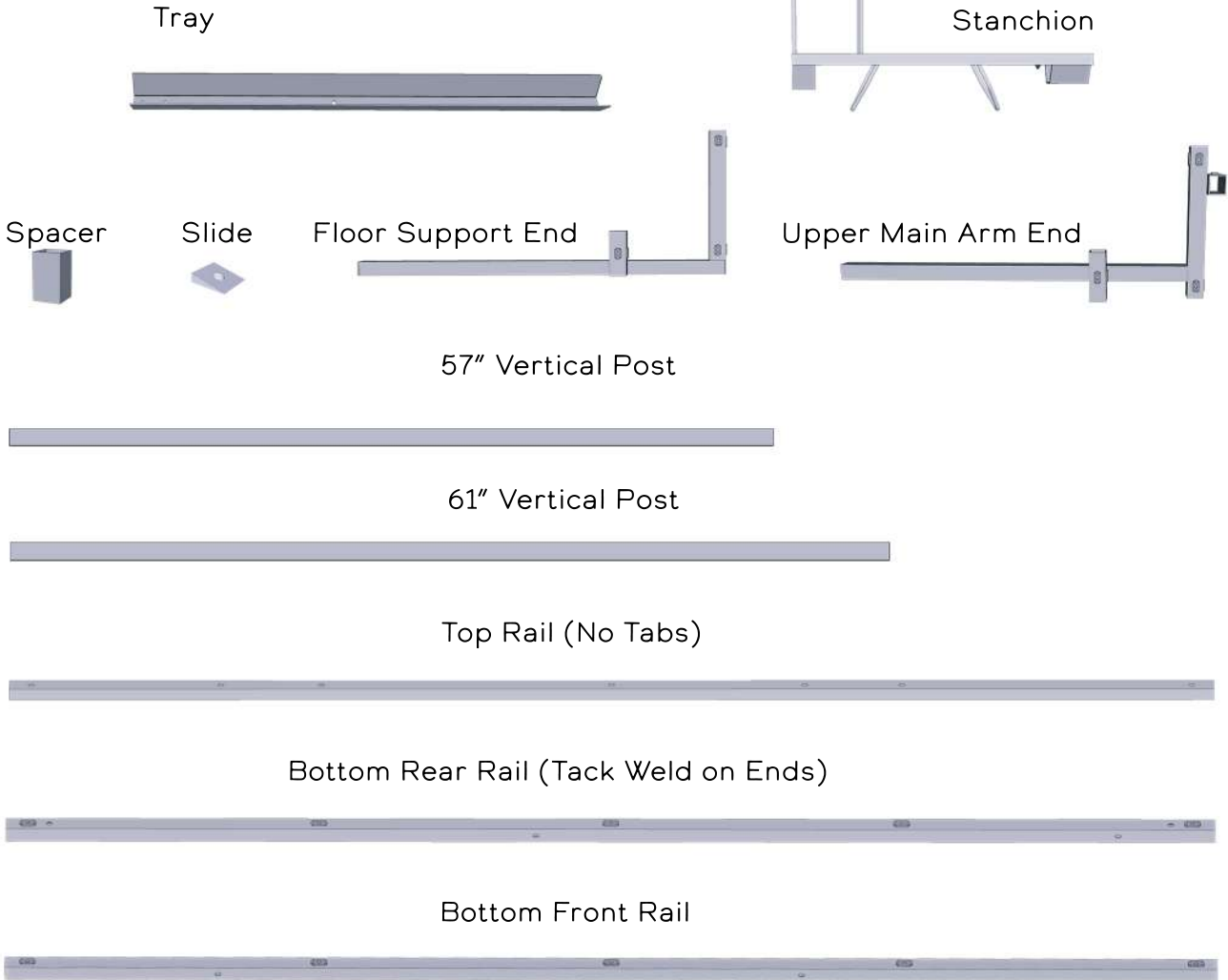
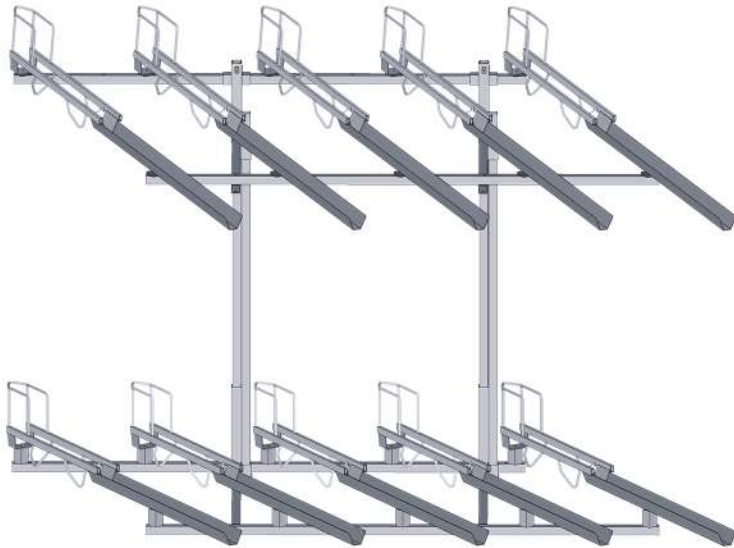

STRAIGHT FORWARD RACK ORIENTATION

BEFORE BEGINNING, DETERMINE IF YOU WOULD LIKE YOUR RACK TO ANGLE RIGHT OR LEFT

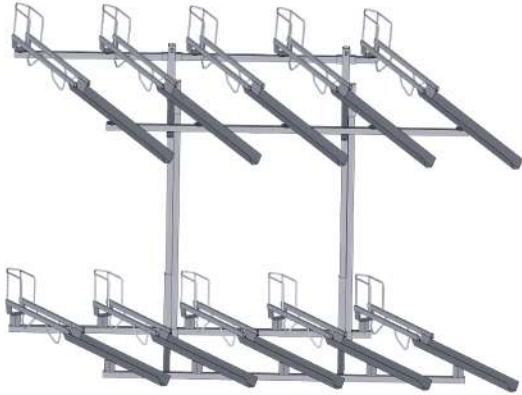

Right Angled Straight Forward

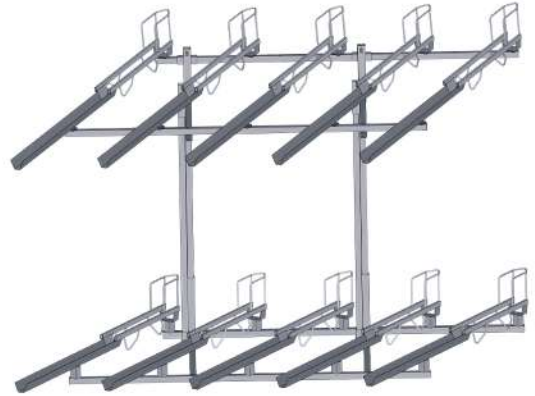

Left Angled Straight Forward

Front View



Rear View



Front View



Top View



Front View



Rear View



Front View



Top View



STEP ONE:

Locate the Bottom Front Rail (No dot on the ends) and the Floor Support Ends. Lay out on the floor, as shown.

Attach the Bottom Front Rail to the Floor Supports using (2) 5/16" x 2" Bolts and (2) 5/16" Washers.



Front View with Right Angled Rack

STEP TWO:

Locate the Bottom Rear Rail (dots on ends.) Lay out as shown.

Attach the Bottom Rear Rail to the Floor Supports using (2) 5/16 x 2" Bolts and (2) 5/16" Washers.



Rear View of Right Angled Rack

STOP!

Steps 1 & 2 show pictures of a right angled orientation. To achieve a left angled rack, you need to spin only the rails 180 degrees, as shown.



Rear View of Left Angled Rack

STEP THREE: Pre-Assemble the Trays

Locate the Stanchions and Trays.

Flip a Stanchion and Tray upside down. Align the 2 holes in the Stanchion with the 2 holes in the Tray. The Tray should be on the outside of the Stanchion, as shown.



Place a 1/4" Washer over a 1/4" x 3/4" Bolt. Insert the assembly through one of the holes. Tighten loosely with a 1/4" Washer and 1/4" Stopnut.



Repeat in the open hole, as shown. Tighten using (2) 7/16" Wrenches.



Insert (2) 1/2" x 1" Plugs into the open holes in the front of the Stanchion, as shown.

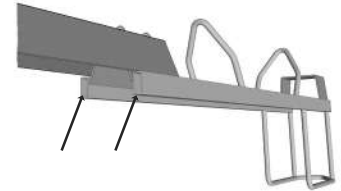

Insert (2) 1/2" x 1" Plugs into the back of the Stanchion, as shown.

Your tray is now complete!



ALL REMAINING STEPS SHOW RIGHT ANGLE ORIENTATION

STEP FOUR:

Place the Spacers over the rear and front weld nuts. Make sure to place these at an angle because the trays will be angled, as shown.

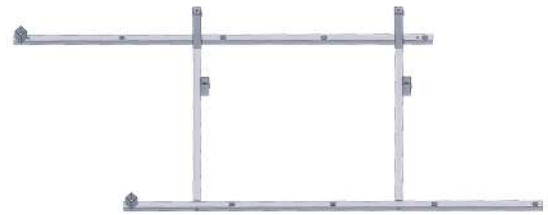

STEP FIVE:

Take the pre-assembled Trays and place them over the Spacers. Align the front and rear holes of the Tray with the holes in the Rails.

Attach the Trays and Spacers to the Rails using 5/16" x 3" Bolts and 5/16" Washers.



STEP SIX:

Locate the (2) 61" Vertical Posts and insert them into the vertical tubes on the rear of the Floor Supports. Secure using 5/16" x 1/2" Bolts.



Next take the (2) remaining 57" Vertical Posts and insert them into the other vertical tubes of the Floor Supports. Secure using 5/16" x 1/2" Bolts.

STEP SEVEN:

Locate the Upper Main Arm Ends. Slide the Arms over the Vertical Posts, as shown.

Decide the height of the second tier. We recommend making the rear portion of the Upper Main Arms flush with the top of the 61" Vertical Posts.

Then, using 5/16" x 1/2" Bolts, secure the arms to the Vertical Posts at the desired height. Make sure the Upper Main Arms are level when you tighten the 57" Vertical Posts in place.

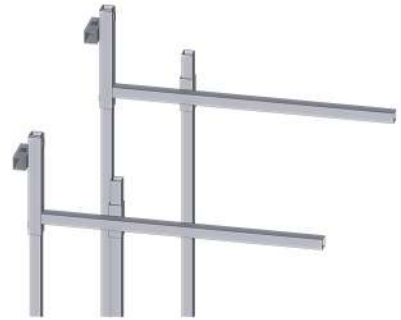

STEP EIGHT:

Locate (1) Top Rail (only has through holes.)

Place the rail on the front of the Upper Main Arms corresponding with the placement of the Bottom Front Rail.



Align the holes on the rail with the holes in the Upper Main Arms, as shown. Secure the rail to the Arms using 5/16" x 3" Bolts, 5/16" Washers, and 5/16" Stopnuts. Tighten.

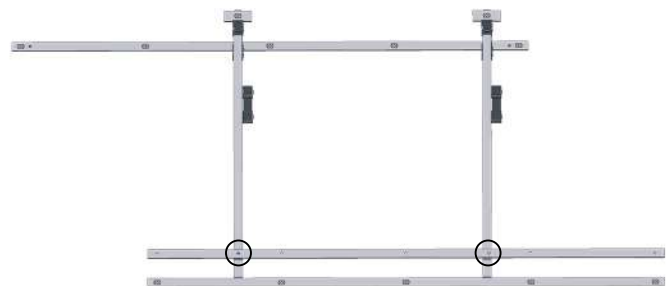

Top View, Trays Removed for Easier Viewing

STEP NINE:

Locate the other Top Rail. Slide it through the horizontal tubes on the back of the Upper Main Arms.

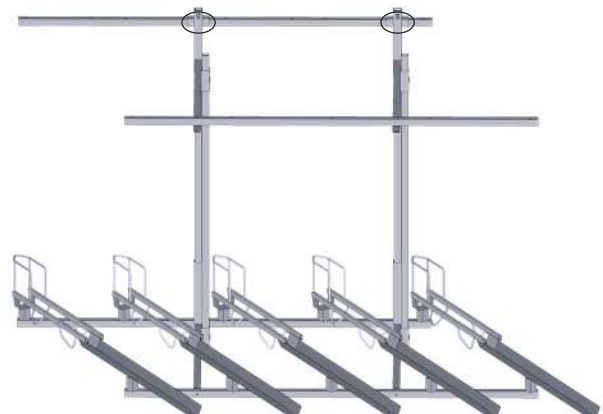

STEP TEN:

The next step is aligning the Top Rear Rail.

This is easiest done by taking a Tray and setting it on the rails with the front hole of the Tray on the end of the Top Front Rail.

Temporarily place a $5/16"$ x $2-1/2"$ Bolt in the hole but do not secure. Adjust the Rear Rail by sliding it so the back hole in the Tray lines up with the hole in the Rail, as shown.

Secure the Rear Rail to the Upper Main Arms using $5/16"$ x $1/2"$ Bolts. Tighten Loosely.

The tray attaches permanently in Step 11.



STEP ELEVEN:

The last step is to attach the Tray Assemblies to the Second Tier of the structure. Start at one end of the structure and place slides on the rails so the holes line up. Remember to angle the Slides the same as the Tray Assemblies.

Secure the Tray Assemblies to the rails by inserting a $5/16"$ x $2-1/2"$ Bolt and $5/16"$ Washer through the Tray Assembly, the Slide, and the Rail; securing from below with a $5/16"$ Washer and $5/16"$ Stopnut.

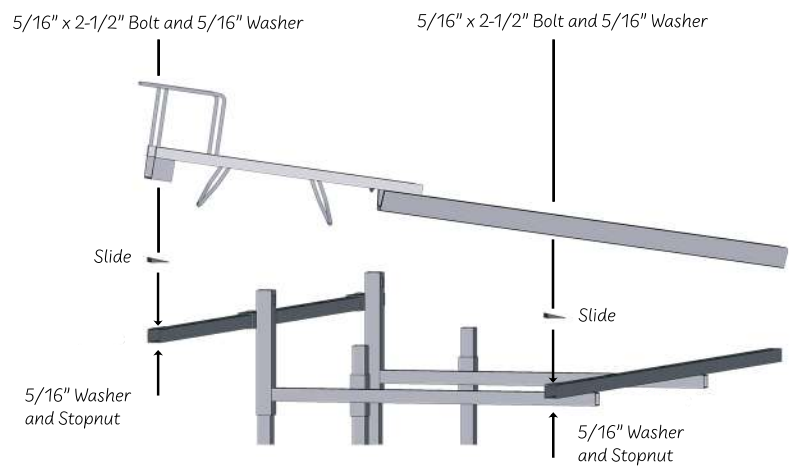

STEP TWELVE:

Go back through and tighten any loose bolts. Finish the rack by inserting Black Plugs into any exposed ends of Rails and Supports.

Your rack is now complete!

Before loading bikes: If your bike has a rear derailleur it is recommended that the rear derailleur is set to the lowest gear (the largest rear chain ring) to prevent chain or derailleur damage

